



Vizimax
A PGC Company

STM045000

Controlled Switching Enclosure
with Integrated Bypass for 3-p & 1-p operated MV switchgear
Datasheet



STM045000-SP-en
2026-02-25

©2025 Vizimax Inc. All rights reserved

Table of contents

| | |
|--------------------------------------------------------------------------------------------|-----------|
| Table of contents..... | 1 |
| List of tables..... | 2 |
| List of figures | 2 |
| 1 Controlled switching enclosure – STM045000 | 3 |
| 1.1 Product Highlight | 3 |
| 1.2 Benefits..... | 3 |
| 1.3 The STM045000 cabinet..... | 4 |
| 1.4 Built-in controller..... | 4 |
| 1.5 Compliance and certifications | 4 |
| 1.6 Product environment..... | 5 |
| 1.7 Built-in bypass logic..... | 7 |
| 1.8 Local/remote function selector | 8 |
| 1.9 Communication ports and options..... | 8 |
| 1.10 Communications and data transfer solutions..... | 8 |
| 1.11 STM045000 enclosure connection..... | 9 |
| 2 Terminal blocks & sensors in MV switchgear | 13 |
| 2.1 Example of terminal blocks & wiring – MV switchgear | 15 |
| 3 Instrumentation cables between Vizimax enclosure and switchgear | 16 |
| 4 Technical specifications..... | 17 |
| 4.1 Operating characteristics..... | 17 |
| 4.2 Physical dimensions | 18 |
| 5 Ordering Information..... | 19 |
| 5.1 Base models..... | 19 |
| 5.2 Frequently ordered options | 19 |

List of tables

| | | |
|---------|-----------------------------------------------------------------------|----|
| Table 1 | Circuit Breaker / Switchgear type vs load switching application | 3 |
| Table 2 | STM045000 terminal block identification | 11 |
| Table 3 | STM045000 operating characteristics | 17 |
| Table 4 | STM045000 physical dimensions | 18 |

List of figures

| | | |
|----------|---------------------------------------------------------------------------------------|----|
| Figure 1 | STM045000 – Example of controlling 3-pole operated MV switchgear or RMU | 6 |
| Figure 2 | STM045000 – Example of controlling 3 1-pole VCBs for filter/cap. bank switching | 6 |
| Figure 3 | STM045000 front panel padlockable bypass selector | 7 |
| Figure 4 | STM045000 front panel padlockable local/remote selector | 8 |
| Figure 5 | STM045000 terminal blocks location in enclosure | 9 |
| Figure 6 | STM045000 terminal blocks identification | 10 |
| Figure 7 | STM045000 – Example of suggested terminal blocks installed in MV switchgear | 15 |
| Figure 8 | STM045000 mounting points and external dimensions | 18 |

1 Controlled switching enclosure – STM045000

1.1 Product Highlight

The VIZIMAX Controlled Switching Enclosure – STM045000 is a ready to use, control solution for 1, 2 or 3 phase, indoor or outdoor MV switchgear or MV poles, with spring-loaded or electromagnetic mechanisms. It improves the switching of multiple load types.

Table 1 Circuit Breaker / Switchgear type vs load switching application

| Switched Loads | 1-p operated or single-phase poles | 3-p operated with pole staggering | 3-p operated |
|--------------------|------------------------------------|-----------------------------------|--------------|
| Capacitor banks | ☑ | ☑ | |
| Harmonic filters | ☑ | ☑ | |
| Shunt reactors | ☑ | ☑ | |
| Power transformers | ☑ | | ☑ |
| Power cables | ☑ | | |

1.2 Benefits

- Power transformers: mitigate inrush currents, voltage dips, dissipated energy and stresses, reduce transients, improve power quality and power grid stability.
- Capacitors, filters, reactors, cables: transient-free switching, optimal service life of apparatuses and connected equipment.
- Reactive loads for Volt/Var/PF control and hybrid SVC/Statcom: turn your reactor into a ‘Flexible AC Transmission System’ by enabling the fast switching of capacitors and filters. No service interruption, no delay between operations.
- Grid code compliance and Grid resilience: energize power transformers and meet the requirements of Distribution System Operators without any special design or special transformers.
- Integration of RES (wind, solar, hydro, biomass, etc.), allow DSOs, power producers, project developers, manufacturers (WTGs, PV solar inverters, BESS, etc.) to maximize the use of existing grid infrastructures and power equipment.
- Industry, Transportation, Railway, Large energy consumers: ultimate preservation of MV power transformers, switchgear and sensitive equipment in power infrastructures, compliance with grid codes, improved power quality. For transformers in rectifiers, inverters, drives, power supplies and other power electronics, for EAF, AC & DC traction.

1.3 The STM045000 cabinet

- Construction: painted steel enclosure (L 500 x H 500 x D 250 mm) for wall mount, indoor installation, bottom cable gland plate, panel mount controller, hinged door.
- Terminals suitable for 1, 2, or 3 independent single-phase poles, for 1-p operated switchgear, for 3-p operated apparatuses, for two-phase switchgear...etc.
- Multi-voltage, potential free and isolated SSR outputs (3x Close and 3x Open) for Controlled CLOSE, Controlled OPEN operations.
- Built-in Bypass logic: Controlled / Bypassed mode selector on front panel (pad lockable), system health relay output (dry contact). External (uncontrolled) OPEN operations are performed when bypassed (External CLOSE can be authorized by jumper selection).
- Terminals for: DC power supply input (from MV switchgear or from a substation DC power supply), digital I/Os, current and voltage measurements.
- Versatile sensor inputs: 1 A or 5 A current transformers, MV or LV voltage measurement transformers: $100/\sqrt{3} V_{AC}$ up to $200 V_{AC}$, low energy analog (LEA/LPIT) resistive or capacitive voltage dividers, 0 to $20 V_{AC}$.
- Cabinet delivered after March 1st, 2021 includes Native IEC61850 MMS Server Ed.2 protocol with 'Local / remote' function selector on the cabinet door.
- Optional communication connectivity (100BASE-TX or 100BASE-FX connectivity) and time-synchronization (IRIG-B) Please refer to the smart coding document.

1.4 Built-in controller

- Extreme ruggedness: designed for HV and MV power substations, -40°C to $+70^{\circ}\text{C}$ operating temperature range
- Local/remote web-based operation interface: event journals, statuses and alarms, dashboard, system menu. The last 500 events are stored with waveforms when relevant.
- Waveform recording: Review via VIZIMAX's Waveform Analyzer or COMTRADE export.

1.5 Compliance and certifications



1.6 Product environment

The VIZIMAX Controlled Switching Enclosure – STM045000 accommodates a variety of MV switchgear types and environments:

Discharged capacitor banks

Discharged harmonic filters

Shunt reactors

Measurements & sensors:

- One (1) voltage
- Three (3) currents
- Ambient temperature where relevant

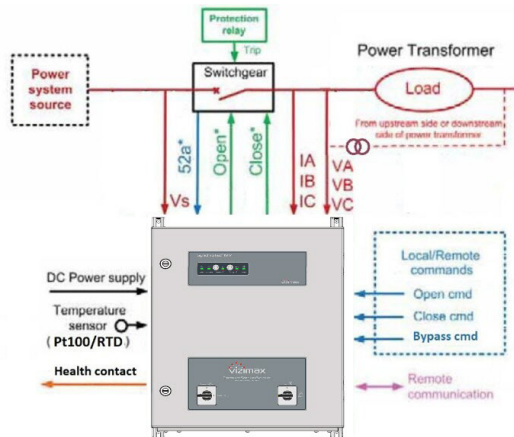
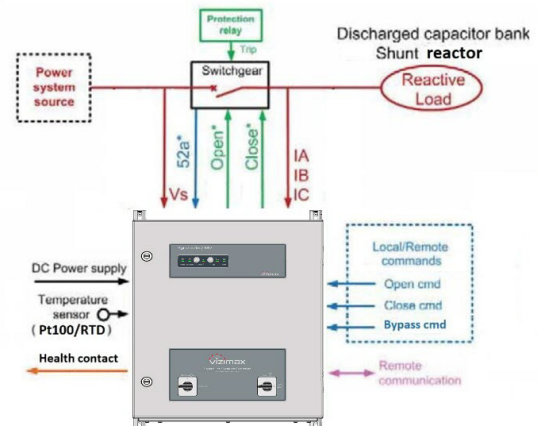

Power transformers (with residual flux calculation)

Measurements & sensors:

- Four (4) voltages
- Three (3) currents
- Ambient temperature where relevant

Partially charged capacitor banks

Partially charged harmonic filters (with fast switching)

Measurements & sensors:

- Three (3) voltages
- Three (3) currents
- Ambient temperature where relevant

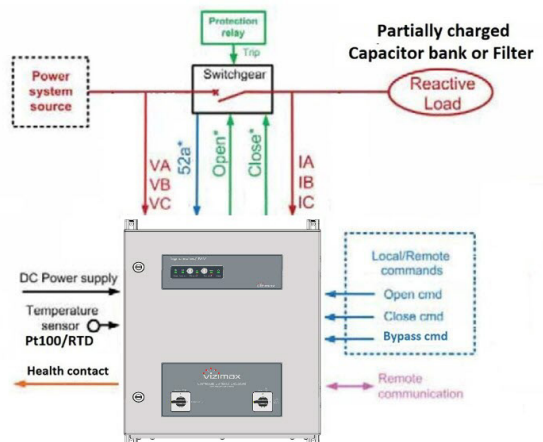

Example 1

Control of 3-pole operated MV switchgear or RMU for energizing a power transformer. Voltage measurement via resistive dividers on the feeder side (x1) and on the load side (x3), plus dedicated current transformers (x3).

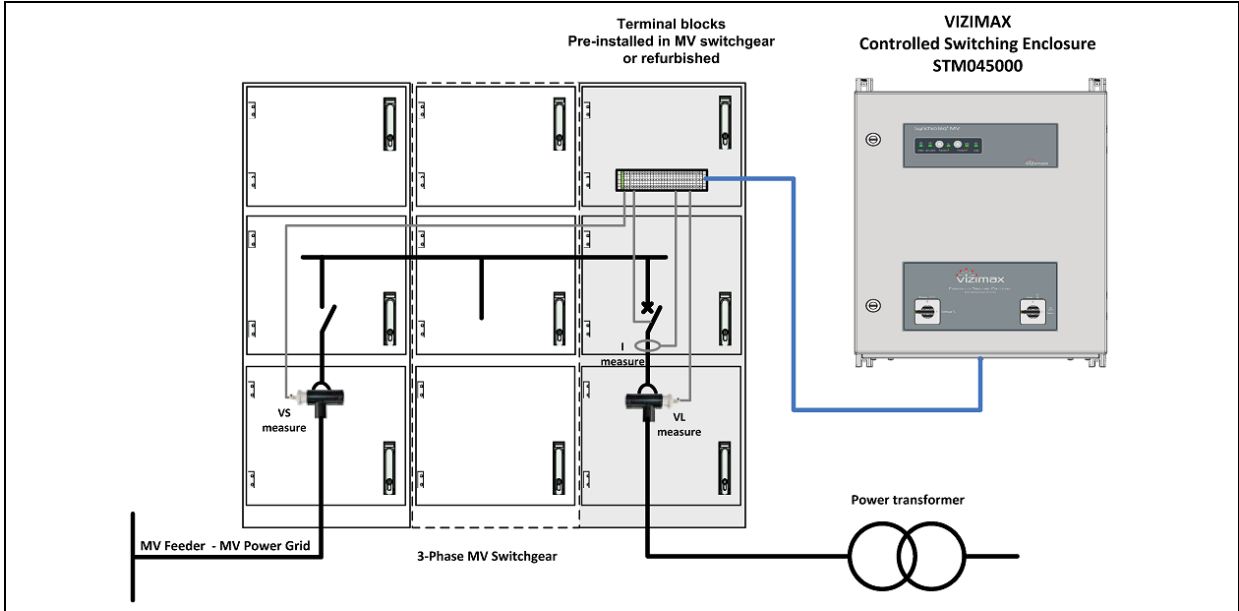

Figure 1 STM045000 – Example of controlling 3-pole operated MV switchgear or RMU

Example 2

Control of three single-phase vacuum circuit breaker (VCB) for filter or capacitor bank switching, with fast-switching mode. Voltage measurements via magnetic/inductive VTs on the feeder side (x3), plus dedicated current transformers (x3).

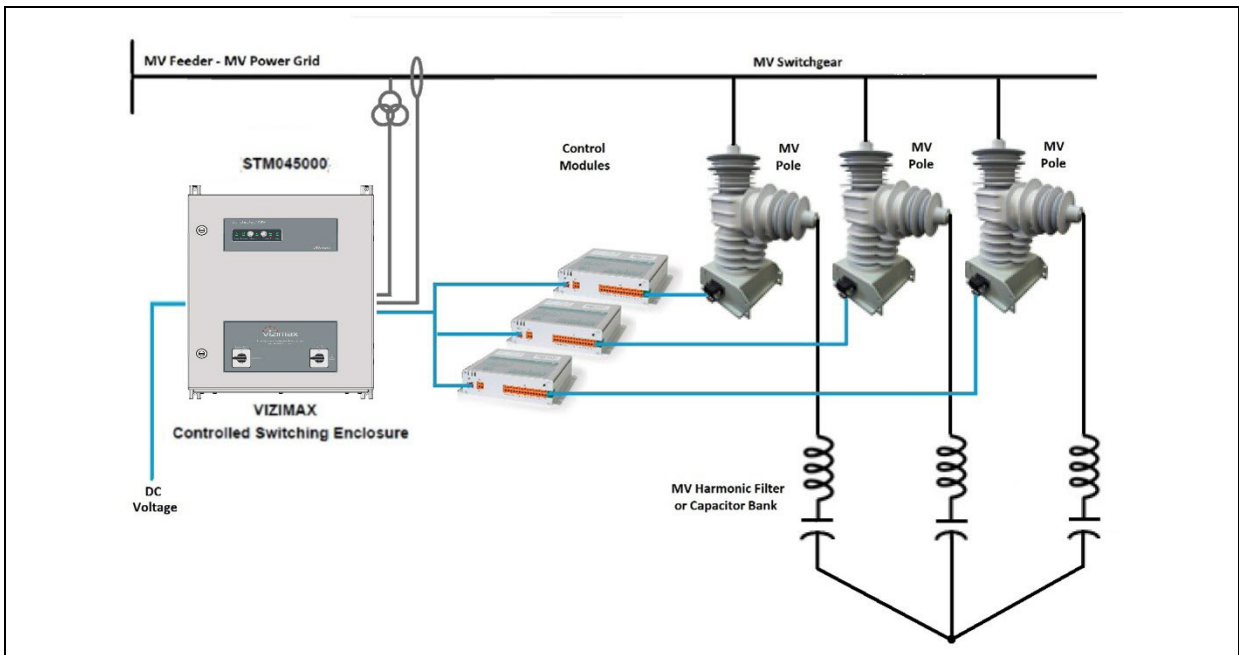

Figure 2 STM045000 – Example of controlling 3 1-pole VCBs for filter/cap. bank switching

1.7 Built-in bypass logic

The VIZIMAX Controlled Switching Enclosure – STM045000 includes a bypass logic being activated through several modes. Once the bypass mode is activated, Open / Close commands are processed as ‘external’ uncontrolled commands.

NOTE The switchgear Close operation when bypassed can be enabled by jumper selection.

Automatic bypass mode

The SynchroTeq controller is automatically bypassed if a system failure or an operational fault condition is detected and reported on the signalization relay output ‘R4’.

Remote bypass mode (by DI via the ‘CSD Enable’ input, or by web command)

The SynchroTeq controller is forced ‘Out of Service’ / ‘Bypassed’ when the ‘CSD Enable’ contact input circuit is opened or when an ‘Out of Service’ command is sent by the commissioning tool (VCT) or through the IEC61850 MMS protocol (if activated).

Manual bypass

The SynchroTeq unit can be manually bypassed using the ‘Bypassed/Controlled’ selector on the front panel. The ‘Bypassed/Controlled’ selector can be padlocked.

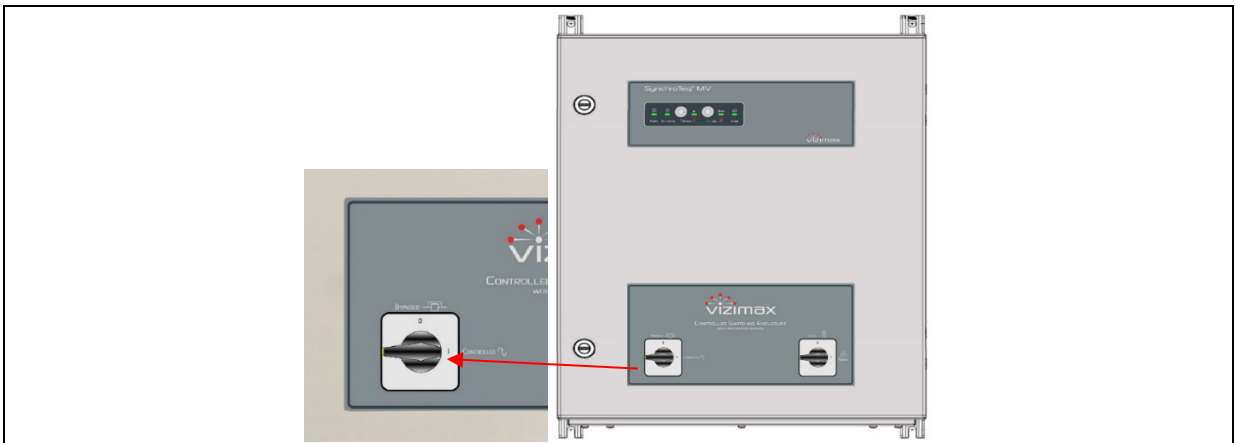

Figure 3 STM045000 front panel padlockable bypass selector

Passive bypass option

With no impact on the price, the passive bypass option (see options) makes it possible to operate the switchgear/CB even though the connected STM045000 cabinet is unpowered or defective.

NOTE When specifying this passive configuration, equipment issuing the OPEN and CLOSE command must be able to supply and sustain up to 3 switchgear coil currents.

This option must be specified in the smart coding form when ordering the STM045000 enclosure.

1.8 Local/remote function selector

A front panel padlockable selector allows manual setting in Local or Remote mode.

This selector activates both:

- The front panel cabinet in local mode (Only SynchroTeq buttons are enabled, depending on the parameterization)
- The ‘local mode’ of the native IEC61850 MMS Server Ed.2 protocol.

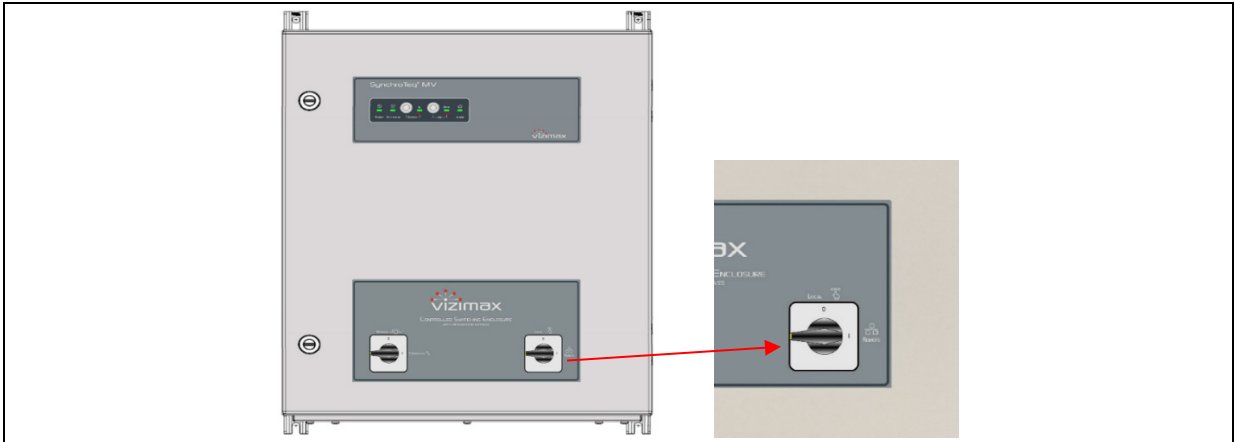

Figure 4 STM045000 front panel padlockable local/remote selector

1.9 Communication ports and options

The SynchroTeq MV controller in the VIZIMAX Controlled Switching enclosure – STM045000 features two (2) 100BASE-TX Ethernet ports (RJ45 connectors).

The following option is available:

STAMMST00 – 100BASE-FX communication port: one 100BASE-FX / multimode fiber-optic interface with ST connectors.

This option is mounted in the STM045000 cabinet. It is installed at VIZIMAX factory and must be ordered with the STM045000 enclosure. Please refer to the STM045000 smart coding form.

1.10 Communications and data transfer solutions

The STM045000 enclosure natively supports the following protocols:

- IEC 61850 MMS Server Ed.2 protocol (including the XCBR control model), for substation automation and SCADA system interfacing
- DNP3.0¹
- Modbus-TCP (Slave)¹

IEC 61850 protocol allows COMTRADE file transfer.

NOTE ¹ Available with SynchroTeq firmware 2.3 and up.

1.11 STM045000 enclosure connection

The interconnection between the VIZIMAX STM045000 enclosure and the MV switchgear is achieved using instrument cables, connected to the MV switchgear bays / to the switchgear control modules and to the terminal blocks in the STM045000 enclosure.

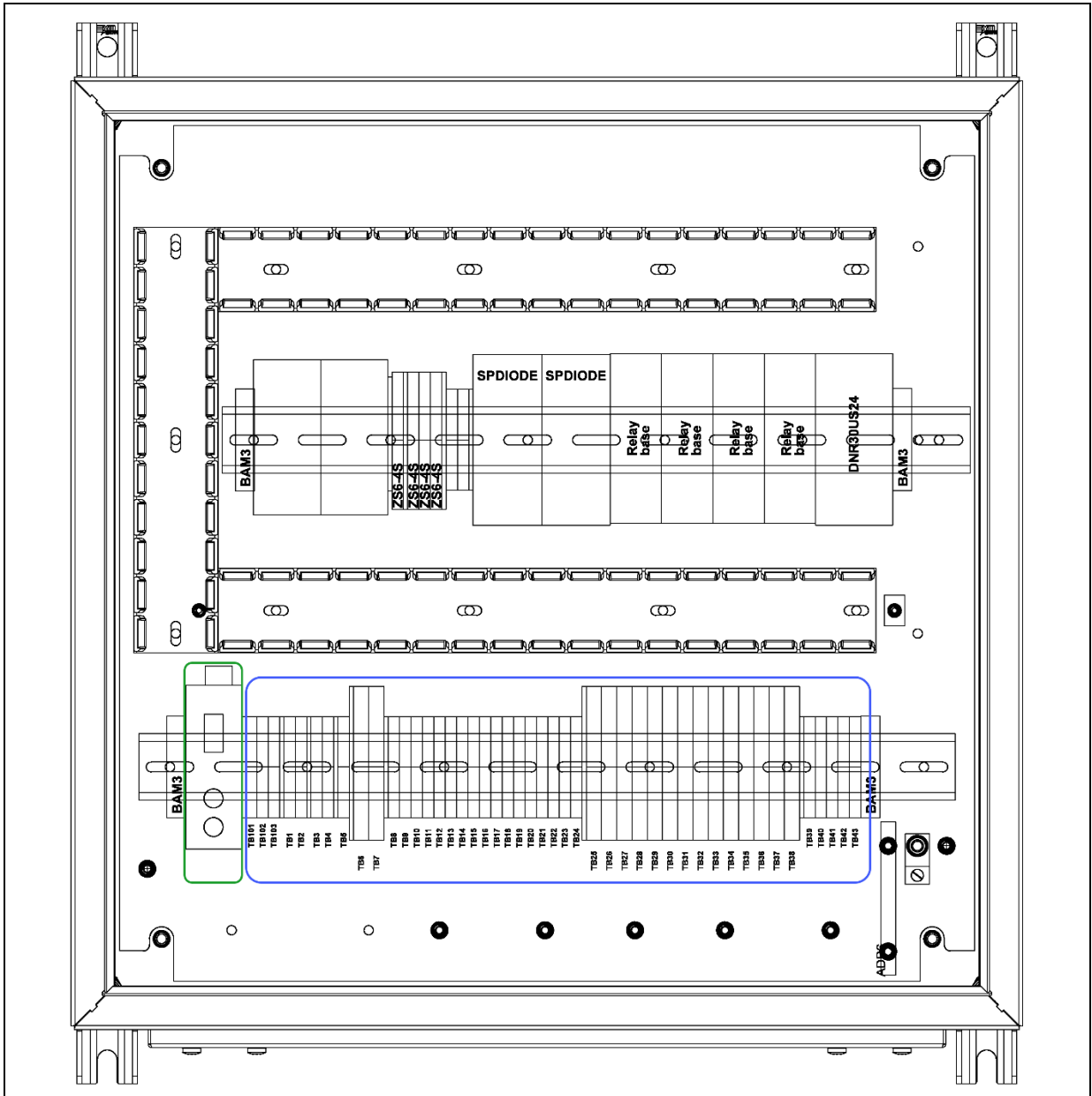

Figure 5 STM045000 terminal blocks location in enclosure

The STM045000 enclosure is equipped with terminal blocks that accommodates the digital inputs / outputs and measurements for three-phase, 3-pole operated or 1-pole operated MV switchgear as well as for MV configurations made of one, two or three single-phase pole(s).

1.11.1 STM045000 terminal blocks identification

The VIZIMAX Controlled Switching Enclosure – STM045000 includes the following terminals.

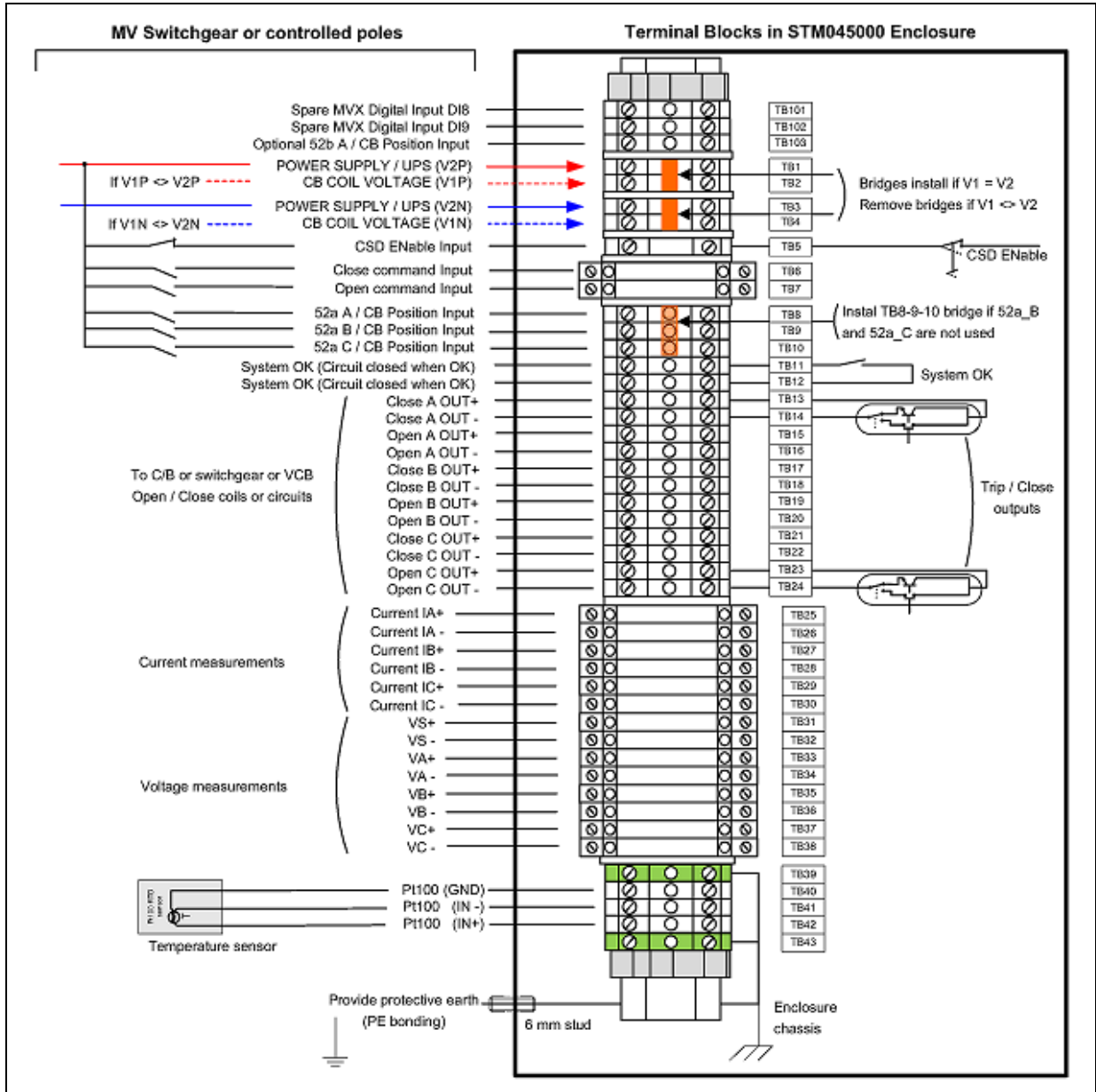

Figure 6 STM045000 terminal blocks identification

Table 2 STM045000 terminal block identification

| Terminal Block Id | Signal Name | Description | Note |
|-------------------|--------------------|-----------------------------------------------------------------------|-------------------------------------------------------|
| TB101 | Spare_MVX_DI8(+) | Spare Digital input SynchroTeq MVX – DI8 (+) | |
| TB102 | Spare_MVX_DI9(+) | Spare Digital input SynchroTeq MVX – DI9 (+) | |
| TB103 | Opt_52b_A | 52b / CB position contact input (Phase A) | Optional signal |
| | Spacer | | |
| TB1 | V2P (+) | Power supply to STM045000 (+) | TB1-TB2 bridged ¹ |
| TB2 | V1P (+) | CB Coil Voltage monitoring (+) | |
| | Spacer | | |
| TB3 | V2N (-) | Power supply to STM045000 (-) | TB3-TB4 bridged ² |
| TB4 | V1N (-) | CB Coil Voltage monitoring (-) | |
| | Spacer | | |
| TB5 | CSD EN | CSD Enable input signal (Active “high”) | See Note 3 |
| TB6 | CLOSE_CMD | CLOSE Command input | With test plug and disconnect switch |
| TB7 | OPEN_CMD | OPEN Command input | With test plug and disconnect switch |
| TB8 | 52a A/ CB position | 52a / CB position contact input (Phase A) | See Note 4 |
| TB9 | 52a B/ CB position | 52a / CB position contact input (Phase B) | |
| TB10 | 52a C/ CB position | 52a / CB position contact input (Phase C) | |
| TB11 | System OK (common) | SynchroTeq MV System OK – Dry contact (System OK = Contact is closed) | |
| TB12 | System OK (NO) | | |
| TB13 | Close A OUT+ | CLOSE coil driver outputs (Phase A) | |
| TB14 | Close A OUT- | | |
| TB15 | Open A OUT+ | OPEN coil driver outputs (Phase A) | |
| TB16 | Open A OUT- | | |
| TB17 | Close B OUT+ | CLOSE coil driver outputs (Phase B) | |
| TB18 | Close B OUT- | | |
| TB19 | Open B OUT+ | OPEN coil driver outputs (Phase B) | |
| TB20 | Open B OUT- | | |
| TB21 | Close C OUT+ | CLOSE coil driver outputs (Phase C) | |
| TB22 | Close C OUT- | | |
| TB23 | Open C OUT+ | OPEN coil driver outputs (Phase C) | |
| TB24 | Open C OUT- | | |
| | Spacer | | |
| TB25 | Current IA+ | Current input, phase A | With test plug and disconnect switch and shorting bar |
| TB26 | Current IA- | | |
| TB27 | Current IB+ | Current input, phase B | With test plug and disconnect switch and shorting bar |
| TB28 | Current IB- | | |

| Terminal Block Id | Signal Name | Description | Note |
|----------------------------------------------------------------------------------------------------------------------------------------------------------------------------------------------------------------------------------------------------------------------------------------------------------------------------------------------------------------------------------------------------------------------------------------------------------------------------------------------------------------------------------------------------------------------------------------------------------------------------------------------------------------------------------------------------------------------------------------------------------------------------------------|-------------|-------------------------------------------------------------|-------------------------------------------------------|
| TB29 | Current IC+ | Current input, phase C | With test plug and disconnect switch and shorting bar |
| TB30 | Current IC- | | |
| | Spacer | | |
| TB31 | VS (+) | Source Voltage input (phase A) | With test plug and disconnect switch |
| TB32 | VS (-) | | |
| TB33 | VA (+) | Load Voltage input, (phase A) | With test plug and disconnect switch |
| TB34 | VA (-) | | |
| TB35 | VB (+) | Load Voltage input (phase B) | With test plug and disconnect switch |
| TB36 | VB (-) | | |
| TB37 | VC (+) | Load Voltage input (phase C) | With test plug and disconnect switch |
| TB38 | VC (-) | | |
| | Spacer | | |
| TB39 | GROUND | Ground | |
| TB40 | Pt100_PE | Pt100 RTD sensor common to P.E. ground | See Note 5 |
| TB41 | Pt100_S- | Pt100 RTD sensor common to measurement input | See Note 5 |
| TB42 | Pt100_S+ | Pt100 RTD + wire connected to measurement input | See Note 5 |
| TB43 | GROUND | Ground | |
| Protective Earth (GND / PE) | | Enclosure chassis to be bonded to External Ground Stud 6 mm | |
| <p>¹ If the coil voltage differs from power supply voltage a) remove the bridge TB1-TB2, then b) connect the C/B coil voltage (+) to TB2.</p> <p>² If the coil voltage differs from power supply voltage a) remove the bridge TB3-TB4, then b) connect the C/B coil voltage (-) to TB4.</p> <p>³ CSD_Enable input in series with the Bypass switch on the STM045000's front panel (internally wired to STMVX DI4 input). Connect TB5 to TB1 (V2P) if the remote Bypass control input is not used.</p> <p>⁴ For proper operation of SynchroTeq MVX, all three 52a signals must be wired. Install provided jumper to bridge TB8-9-10 terminals when using only 52a_A.</p> <p>⁵ For 3 wires Pt100 RTD temperature sensor type.</p> | | | |

2 Terminal blocks & sensors in MV switchgear

When practically feasible and convenient a suitable terminal block will be integrated in the controlled MV switchgear (LV compartment) for its connection to the VIZIMAX Controlled Switching Enclosure – STM045000. This terminal block shall be personalized depending on the installation settings and switchgear configuration.

Example – Control of a 3-pole (simultaneous) operated MV switchgear for energizing a power transformer:

Power sources

- Main switchgear power supply (V2): used for powering the STM045000 cabinet
- CB coil voltage (V1), when different than V2: for monitoring and compensation purposes.

Digital I/Os

- CSD Enable input (optional): remote control of the SynchroTeq unit's mode when the STM045000's front panel selector is on 'controlled' position.
 - ON = SynchroTeq is 'In-service' = controlled switching
 - OFF = SynchroTeq is 'Out-of-service' = SynchroTeq is Bypassed = random switching
 - Connect TB5 to TB1 (or TB2 if V1=V2) if the remote control is unused.
- Close command input
- Open command input
- One (1) 52a input: CB position contact (jumper on TB8-9-10 must be installed)
- System OK output: relay output, health status. Contact closed = system OK
- One (1) Close OUT: power output, CLOSE coil driver
- One (1) Open OUT: power output, OPEN/TRIP coil driver

Measurement transformers

- V Source – Feeder or power grid voltage:
 - One (1) voltage measurement – Phase A only.
 - Measurement device: magnetic PT/VT, capacitive divider, resistive divider.
 - Dual range: traditional instrument transformer (0 to 200 V_{AC}) or Low Energy Analog “LEA/LPIT” (0 to 20 V_{AC})
- Load Currents
 - Three (3) current measurements – Phases A, B, C.
 - Current measurement can be done upstream or downstream of the CB.
 - 1Amp or 5Amp, from inductive current transformer cores.
- V Load – Load side/transformer voltages:
 - Three (3) voltage measurements – Phases A, B, C.
 - Measurement device: magnetic PT/VT, capacitive divider, resistive divider.
 - Dual range: traditional instrument transformer (0 to 200 V_{AC}) or Low Energy Analog “LEA/LPIT” (0 to 20 V_{AC})

Analog I/O

- Internal switchgear temperature:
 - Pt100 / RTD sensor – Three wires type

2.1 Example of terminal blocks & wiring – MV switchgear

Configuration example:

- Three (3) simultaneous pole operated (gang operated) MV switchgear
- MV switchgear with four (4) resistive dividers
- Switchgear coil voltage matching the main switchgear’s power supply voltage ($V1 = V2$)
- CSD ENable: control from MV switchgear.

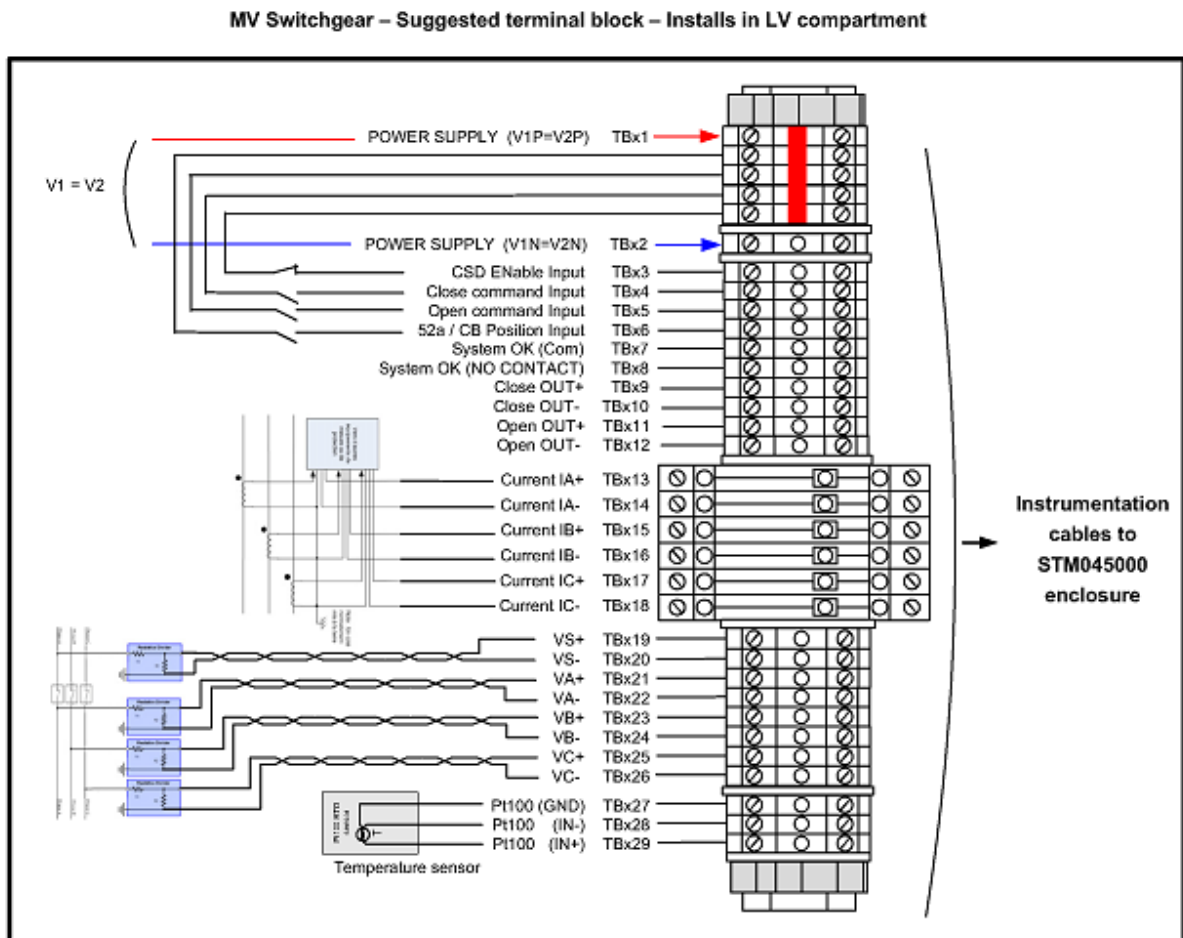

Figure 7 STM045000 – Example of suggested terminal blocks installed in MV switchgear

NOTE The PT100 RTD sensor preferably installs in the ‘breaking section’ (enclosure of the controlled CB) in the MV switchgear.

NOTE Please refer to the STM045000 User Guide for more examples.

3 Instrumentation cables between Vizimax enclosure and switchgear

The instrumentation cables, supplied by the customer or its electrical contractor or system integrator, are used to connect the VIZIMAX Controlled Switching Enclosure – STM045000 to the controlled medium voltage switchgear bay.

The instrumentation cables required between the MV switchgear and the VIZIMAX Controlled Switching Enclosure are dictated by the switched load type and the internal switchgear configuration (pole operated type, voltage measurement device, coil monitoring power supply and CSD enable command).

NOTE Please refer to the STM045000 User Guide for more details.

4 Technical specifications

4.1 Operating characteristics

Table 3 STM045000 operating characteristics

| Characteristics | Value | Standards reference |
|--------------------------------------------------------------------------------------------------------------------------------------------------------------------------------------------------------------------------------------------------------------------------------------------------------------------------------------------------------------------------|----------------------------------------------------------------------------------------------------------------------------------------------------------------------------------------------------------------------------------------------------------------------------------------------------------------------------------------|---------------------|
| Operating temperature | -40 to +70 °C | UL 61010-1 |
| Storage temperature | -50 to +85 °C | |
| Rated Power | <p>20 W max (without option)</p> <p>The external power supply must be able to sustain a 25 A cold start current for 2 ms at unit start up.¹</p> <p>When the optional SynchroTeq Communication Module (RWK000016) is included in the enclosure, the external power supply must be sized accordingly to feed this module.</p> | |
| Maximum altitude | 2 km | |
| Maximum Relative humidity (R.H.) | 95% without condensation | IEC 60068-2-30 |
| Enclosure | IP54 | |
| <p>¹ The SynchroTeq MV power supply includes a power reserve capable of sustaining a 100 ms power interruption. At energization, the energy storage components may induce a 25 A cold start current for less than 2 ms, down to nominal after no more than 200 ms. The external power supply must be able to sustain this inrush current when energizing.</p> | | |

NOTE Please refer to SynchroTeq MV datasheet for SynchroTeq MV unit specifications.

4.2 Physical dimensions

Table 4 STM045000 physical dimensions

| Physical dimensions | Value |
|---------------------|--------------------------|
| Dimension (L-H-D) | 500 mm x 500 mm x 250 mm |
| Weight | 22.7 kg (50.0 lb) |

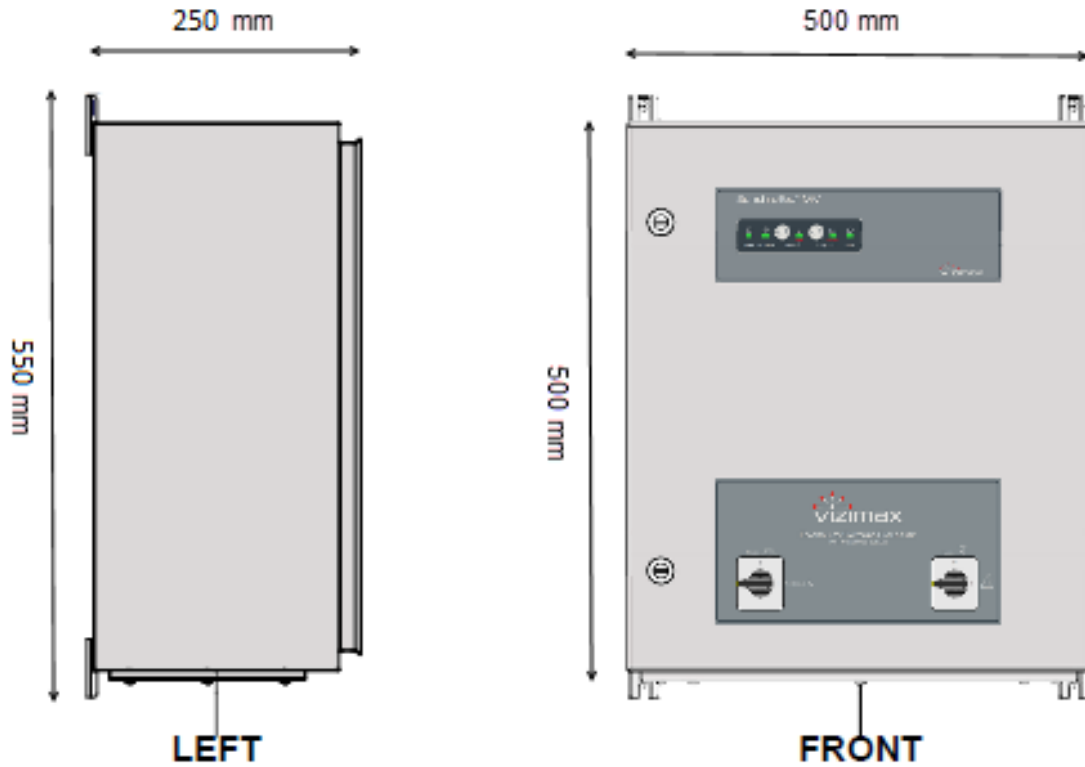

Figure 8 STM045000 mounting points and external dimensions

NOTE Please refer to STM045000 User Guide for detailed enclosure specifications.

5 Ordering Information

NOTE These specifications are subject to change without prior notice.

5.1 Base models

STM045000 **Controlled Switching Enclosure** – This metal paint enclosure includes a SynchroTeq MV unit and a built-in Bypass logic, for controlled operations of MV switchgear.

- Standard communication link: 100BASE-TX (copper Ethernet / RJ45 connector).
- Time synchronization via NTP-SNTP time server on Ethernet, via IEEE PTP 1588 clock source on Ethernet, or via manual synchronization from a connected computer.
- Native connectivity:
 - IEC 61850 MMS Server Ed.2 protocol (including the XCBR control model), for substation automation and SCADA system interfacing
 - DNP3.0
 - Modbus-TCP (Slave)

Power supply versions

24 V_{DC} / 48 V_{DC} / 110 V_{DC} / 125 V_{DC}

Bypass configurations

- Magnetic contactors bypass logic
- Passive bypass logic (with 2 diode trios)

5.2 Frequently ordered options

NOTE To select ordering options such as, power supply voltage, bypass configuration, IRIG-B synchronization or communication options, please refer to the 'Smart Coding' document 'STM045000-SC' available on the VIZIMAX web site <https://VIZIMAX.com>

RWC0Y0001 IRIG-B time-synchronization interface:

- IRIG-B000/B004 IEEE C37.118
- IRIG-B000/B004 IEEE-1344
- IRIG-B003

STAMMST00 Media converter – 100BASE-TX to 100BASE-FX / fiber-optic interface
– Fiber-optic: multimode type with ST connectors.

NOTE Vizimax also offers commissioning and training services: for more details, please contact us.

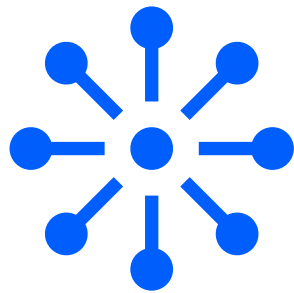

Vizimax

A PGC Company

support@vizimax.com

www.vizimax.com/contact