



Controlled Switching Enclosure with Integrated Bypass for 3-p & 1-p operated MV switchgear

DATASHEET

STM045000

2024-03-27

Reference: 22797: STM045000-SP-en

www.vizimax.com

TABLE OF CONTENTS

CONTROLLED SWITCHING ENCLOSURE - STM045000	3
PRODUCT HIGHLIGHT	3
PRODUCT ENVIRONMENT	5
BUILT-IN BYPASS LOGIC.....	7
LOCAL/REMOTE FUNCTION SELECTOR.....	8
COMMUNICATION PORTS AND OPTIONS	8
STM045000 ENCLOSURE CONNECTION	9
TERMINAL BLOCKS & SENSORS IN MV SWITCHGEAR	13
EXAMPLE OF TERMINAL BLOCKS & WIRING – MV SWITCHGEAR	14
INSTRUMENTATION CABLES BETWEEN VIZIMAX ENCLOSURE AND SWITCHGEAR	15
SPECIFICATIONS	16
ORDERING INFORMATION	18
CUSTOMER SUPPORT	19

CONTROLLED SWITCHING ENCLOSURE - STM045000

PRODUCT HIGHLIGHT

The VIZIMAX Controlled Switching Enclosure - STM045000 – is a ready to use, control solution for 1, 2 or 3 phase, indoor or outdoor MV switchgear or MV poles, with spring-loaded or electromagnetic mechanisms. It improves the switching of multiple load types.

Switched Loads	MV Switchgear types		
	1-p operated or single-phase poles	3-p operated with pole staggering	3-p operated
Capacitor banks	☑	☑	
Harmonic filters	☑	☑	
Shunt reactors	☑	☑	
Power transformers	☑		☑
Power cables	☑		

Benefits:

- Power transformers: mitigate inrush currents, voltage dips, dissipated energy and stresses, reduce transients, improve power quality and power grid stability
- Capacitors, filters, reactors, cables: transient-free switching, optimal service life of apparatuses and connected equipment
- Reactive loads for Volt/Var/PF control and hybrid SVC/Statcom: turn your reactor into a 'Flexible AC Transmission System' by enabling the fast-switching of capacitors and filters. No service interruption, no delay between operations.
- Grid code compliance and Grid resilience: energize power transformers and meet the requirements of Distribution System Operators without any special design nor special transformers
- Integration of RES - wind, solar, hydro, biomass...: allow DSOs, power producers, project developers, manufacturers (WTGs, PV solar inverters, BESS...) to maximise the use of existing grid infrastructures and power equipment
- Industry, Transportation, Railway, Large energy consumers: ultimate preservation of MV power transformers, switchgear and sensitive equipment in power infrastructures, compliance with grid codes, improved power quality. For transformers in rectifiers, inverters, drives, power supplies and other power electronics, for EAF, AC & DC traction...

The STM045000 cabinet:

- Construction: painted steel enclosure (L 500 x H 500 x D 250mm) for wall mount, indoor installation, bottom cable gland plate, panel mount controller, hinged door.
- Terminals suitable for 1, 2, or 3 independent single-phase poles, for 1-p operated switchgear, for 3-p operated apparatuses, for two-phase switchgear...etc.
- Multi-voltage, potential free and isolated SSR outputs (3x Close and 3x Open) for Controlled CLOSE, Controlled OPEN operations.
- Built-in Bypass logic: Controlled / Bypassed mode selector on front panel (pad lockable), system health relay output (dry contact). External (uncontrolled) OPEN operations are performed when bypassed (External CLOSE can be authorised by jumper selection).
- Terminals for: DC power supply input (from MV switchgear or from a substation DC power supply), digital I/Os, current and voltage measurements.
- Versatile sensor inputs: 1Amp or 5Amp current transformers, MV or LV voltage measurement transformers: 100/ $\sqrt{3}$ VAC up to 200VAC, low energy analog (LEA/LPIT) resistive or capacitive voltage dividers, 0 to 20VAC.
- Cabinet delivered after March 1st, 2021 includes Native IEC61850 MMS Server Ed.2 protocol with 'Local / remote' function selector on the cabinet door.
- Optional communication connectivity (100BASE-TX or 100BASE-FX connectivity) and time-synchronization (IRIG-B) Please refer to the smart coding document.

Built-in controller:

- Extreme ruggedness: designed for HV and MV power substations, -40°C to +70°C operating temperature range
- Local/remote web-based operation interface: event journals, statuses and alarms, dashboard, system menu. The last 500 events are stored with waveforms when relevant.
- Waveform recording: Review via VIZIMAX's Waveform Analyzer or COMTRADE export.

COMPLIANCE AND CERTIFICATIONS



PRODUCT ENVIRONMENT

The VIZIMAX Controlled Switching Enclosure - STM045000 – accommodates a variety of MV switchgear types and environments:

- Discharged capacitor banks
- Discharged harmonic filters
- Shunt reactors
 - Measurements & sensors:
 - One (1) voltage
 - Three (3) currents
 - Ambient temperature where relevant

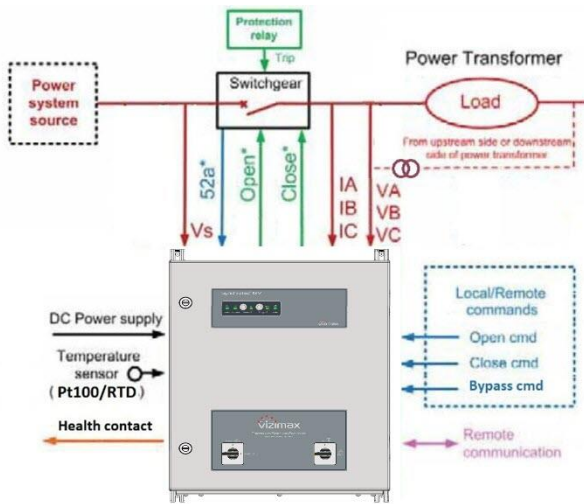
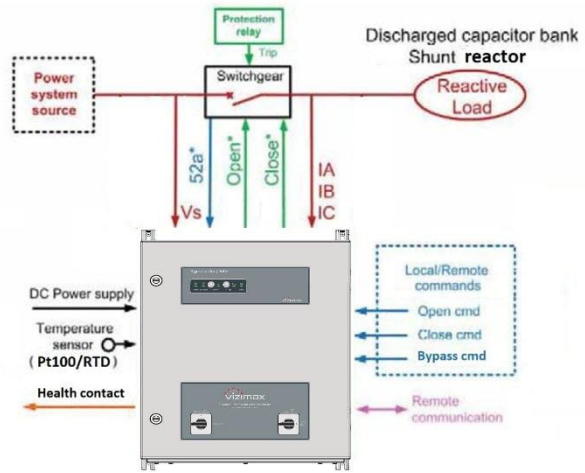

- Power transformers (with residual flux calculation)
 - Measurements & sensors:
 - Four (4) voltages
 - Three (3) currents
 - Ambient temperature where relevant

- Partially charged capacitor banks
- Partially charged harmonic filters (with fast-switching)
 - Measurements & sensors:
 - Three (3) voltages
 - Three (3) currents
 - Ambient temperature where relevant

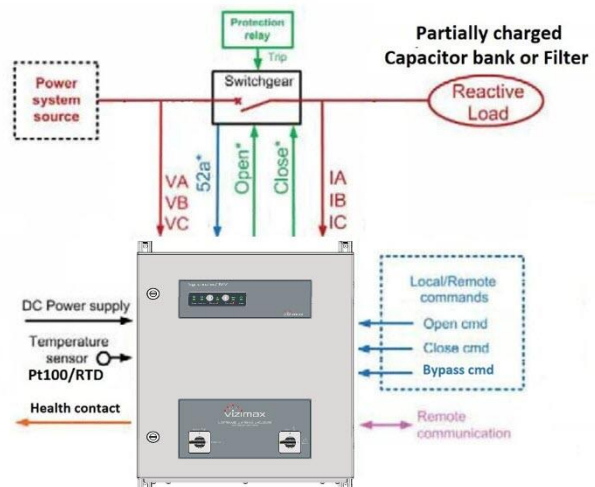

Example 1

Control of 3-pole operated MV switchgear or RMU for energizing a power transformer. Voltage measurement via resistive dividers on the feeder side (x1) and on the load side (x3), plus dedicated current transformers (x3):

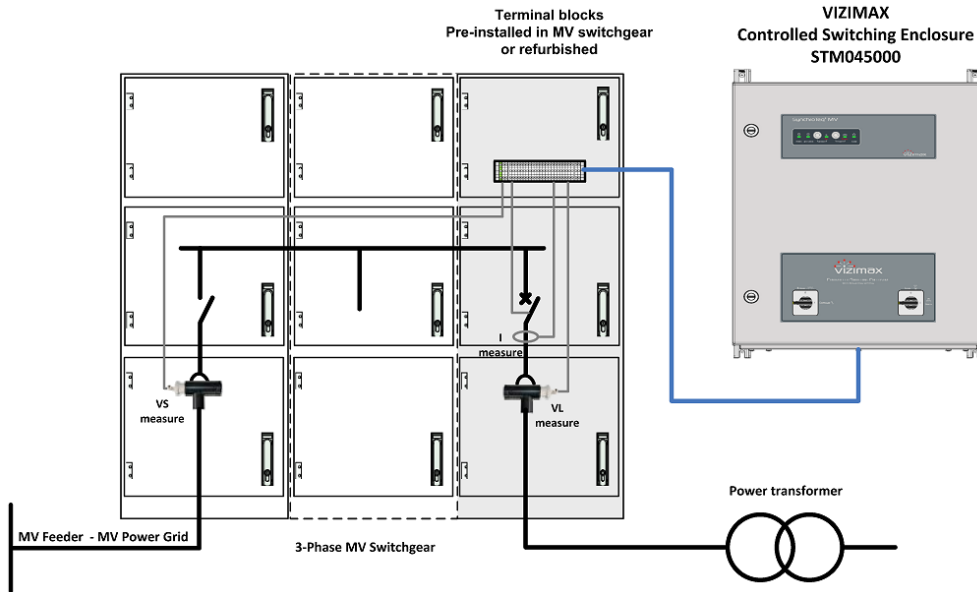

Example 2

Control of three single-phase VCBs (vacuum C/Bs) for filter or capacitor bank switching, with fast-switching mode. Voltage measurements via magnetic/inductive VTs on the feeder side (x3), plus dedicated current transformers (x3):

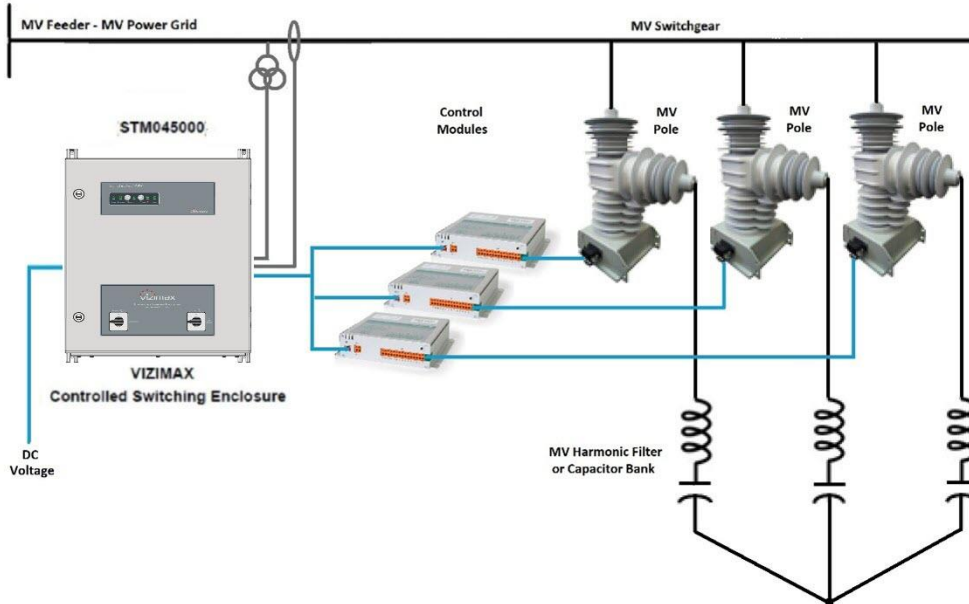

BUILT-IN BYPASS LOGIC

The VIZIMAX Controlled Switching Enclosure - STM045000 – includes a bypass logic being activated through several modes.

Once the bypass mode is activated, Open / Close commands are processed as ‘external’ uncontrolled commands.

Note: the switchgear Close operation when bypassed can be enabled by jumper selection.

- **Automatic bypass mode:**

The SynchroTeq controller is automatically bypassed if a system failure or an operational fault condition is detected and reported on the signalization relay output ‘R4’.

- **Remote bypass mode** (by DI via the ‘CSD Enable’ input, or by web command):

The SynchroTeq controller is forced ‘Out of Service’ / ‘Bypassed’ when the ‘CSD Enable’ contact input circuit is opened or when an ‘Out of Service’ command is sent by the commissioning tool (VCT) or through the IEC61850 MMS protocol (if activated).

- **Manual bypass:**

The SynchroTeq unit can be manually bypassed using the ‘Bypassed/Controlled’ selector on the front panel. The ‘Bypassed/Controlled’ selector is padlockable.

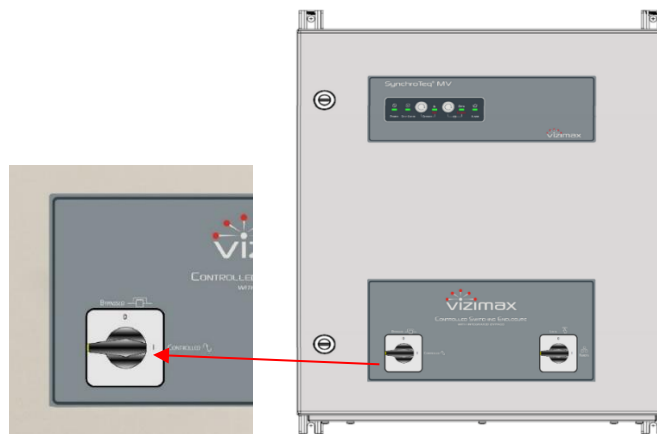

FIGURE 1 FRONT PANEL PADLOCKABLE BYPASS SELECTOR

PASSIVE BYPASS OPTION

With no impact on the price, the passive bypass option (see options) makes it possible to operate the switchgear-C/B even though the connected STM045000 cabinet is unpowered or defective.

NOTE: when specifying this passive configuration, equipment issuing the OPEN and CLOSE command must be able to supply and sustain up to 3 switchgear coil currents.

This option must be specified in the smart coding form when ordering the STM045000 enclosure.

LOCAL/REMOTE FUNCTION SELECTOR

A front panel padlockable selector allows to manually set the unit in 'Local or Remote' mode.

This selector activates both:

- The front panel cabinet in local mode (Only SynchroTeq buttons are enabled, depending on the parameterization)
- The 'local mode' of the native IEC61850 MMS Server Ed.2 protocol.



FIGURE 2 FRONT PANEL PADLOCKABLE LOCAL/REMOTE SELECTOR

COMMUNICATION PORTS AND OPTIONS

The SynchroTeq MV controller in the VIZIMAX Controlled Switching enclosure - STM045000 – features two (2) 100BASE-TX Ethernet ports (RJ45 connectors).

The following options are available:

STAMMST00 - 100BASE-FX communication port: one 100BASE-FX / multimode fiber-optic interface with ST connectors.

RWK000016 - SynchroTeq Communication Module: one 100BASE-TX port (RJ45) + one 100BASE-FX / multimode fiber optic port (ST connectors) + two serial ports. Supported protocols: IEC61850 Server Ed.1, Modbus Slave (TCP and RTU), DNP3 Slave.

Both options are mounted in the STM045000 cabinet, and they are mutually exclusive. They are installed at VIZIMAX factory and must be ordered with the STM045000 enclosure. Please refer to the STM045000 smart coding form.

STM045000 ENCLOSURE CONNECTION

The interconnection between the VIZIMAX STM045000 enclosure and the MV switchgear is achieved using instrument cables, connected to the MV switchgear bays / to the switchgear control modules and to the terminal blocks in the STM045000 enclosure.

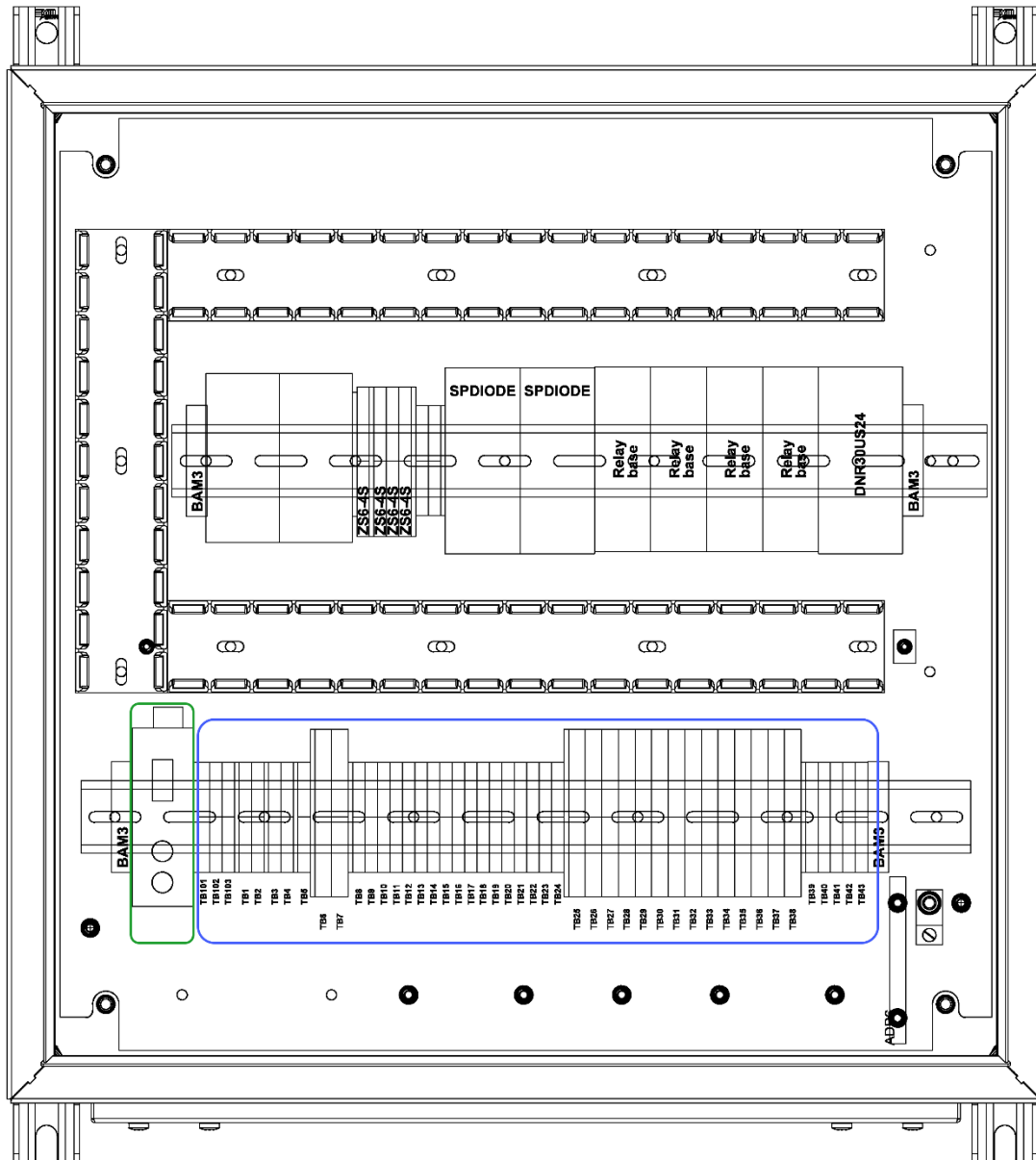

FIGURE 3 TERMINAL BLOCKS LOCATION IN STM045000 ENCLOSURE

The STM045000 enclosure is equipped with terminal blocks that accommodates the digital inputs / outputs and measurements for three-phase, 3-pole operated or 1-pole operated MV switchgear as well as for MV configurations made of one, two or three single-phase pole(s).

STM045000 TERMINAL BLOCKS IDENTIFICATION

The VIZIMAX Controlled Switching Enclosure - STM045000 – includes the following terminals.

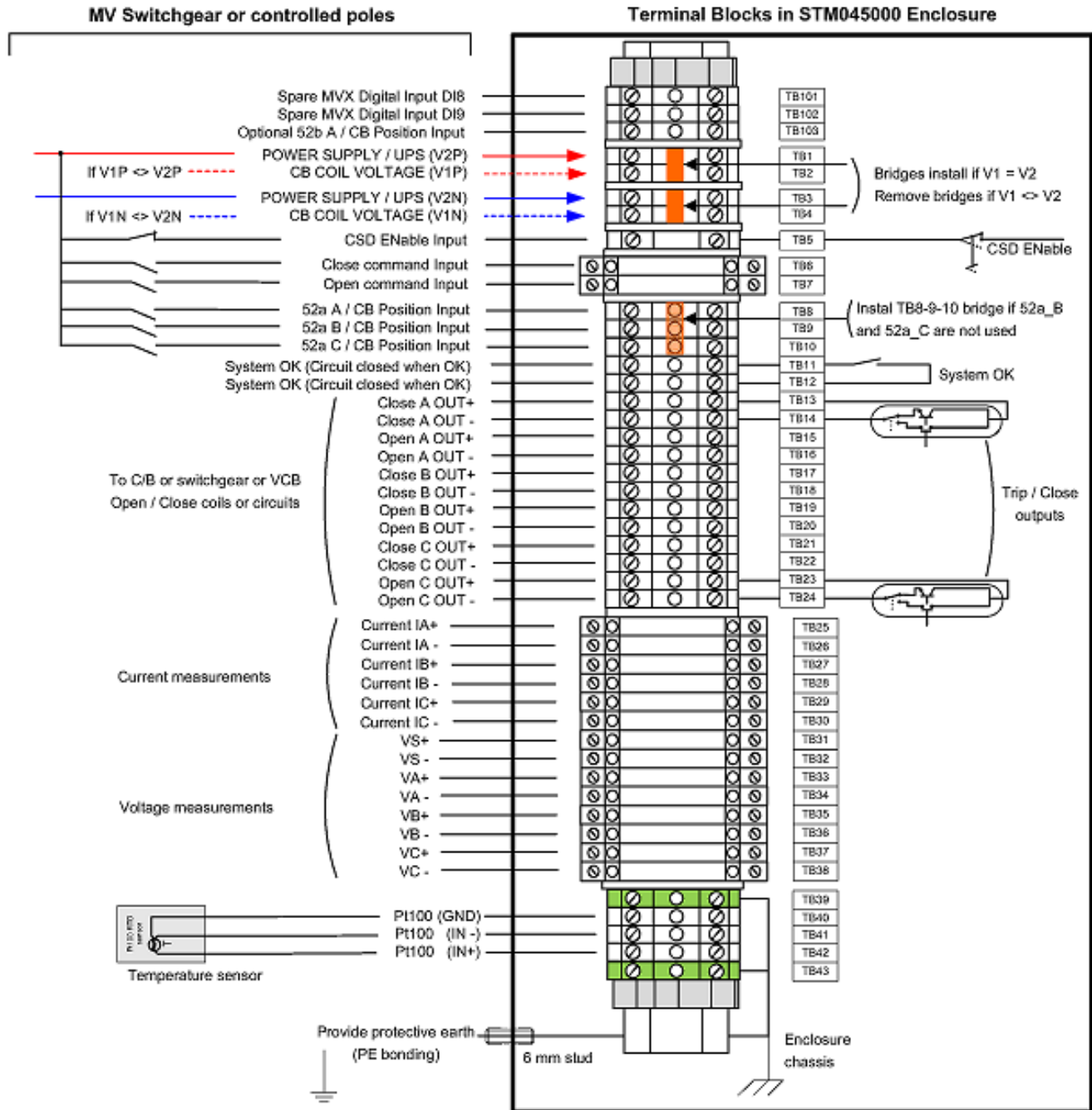

FIGURE 4 STM045000 TERMINAL BLOCKS IDENTIFICATION

Table 1 below provides VIZIMAX STM045000 terminal blocks wiring identification.

TABLE 1 STM045000 TERMINAL BLOCKS IDENTIFICATION

Terminal Block Id	Signal Name	Description	Note
TB101	Spare_MVX_DI8(+)	Spare Digital input SynchroTeq MVX – DI8 (+)	
TB102	Spare_MVX_DI9(+)	Spare Digital input SynchroTeq MVX – DI9 (+)	
TB103	Opt_52b_A	52b / CB position contact input (Phase A)	Optional signal
	Spacer		
TB1	V2P (+)	Power supply to STM045000 (+)	TB1-TB2 bridged See Note 1
TB2	V1P (+)	CB Coil Voltage monitoring (+)	
	Spacer		
TB3	V2N (-)	Power supply to STM045000 (-)	TB3-TB4 bridged See Note 2
TB4	V1N (-)	CB Coil Voltage monitoring (-)	
	Spacer		
TB5	CSD EN	CSD Enable input signal (Active “high”)	See Note 3
TB6	CLOSE_CMD	CLOSE Command input	With test plug and disconnect switch
TB7	OPEN_CMD	OPEN Command input	With test plug and disconnect switch
TB8	52a A/ CB position	52a / CB position contact input (Phase A)	See Note 4
TB9	52a B/ CB position	52a / CB position contact input (Phase B)	
TB10	52a C/ CB position	52a / CB position contact input (Phase C)	
TB11	System OK (common)	SynchroTeq MV System OK – Dry contact (System OK = Contact is closed)	
TB12	System OK (NO)		
TB13	Close A OUT+	CLOSE coil driver outputs (Phase A)	
TB14	Close A OUT-		
TB15	Open A OUT+	OPEN coil driver outputs (Phase A)	
TB16	Open A OUT-		
TB17	Close B OUT+	CLOSE coil driver outputs (Phase B)	
TB18	Close B OUT-		
TB19	Open B OUT+	OPEN coil driver outputs (Phase B)	
TB20	Open B OUT-		
TB21	Close C OUT+	CLOSE coil driver outputs (Phase C)	
TB22	Close C OUT-		

Terminal Block Id	Signal Name	Description	Note
TB23	Open C OUT+	OPEN coil driver outputs (Phase C)	
TB24	Open C OUT-		
	Spacer		
TB25	Current IA+	Current input, phase A	With test plug and disconnect switch and shorting bar
TB26	Current IA-		
TB27	Current IB+	Current input, phase B	With test plug and disconnect switch and shorting bar
TB28	Current IB-		
TB29	Current IC+	Current input, phase C	With test plug and disconnect switch and shorting bar
TB30	Current IC-		
	Spacer		
TB31	VS (+)	Source Voltage input (phase A)	With test plug and disconnect switch
TB32	VS (-)		
TB33	VA (+)	Load Voltage input, (phase A)	With test plug and disconnect switch
TB34	VA (-)		
TB35	VB (+)	Load Voltage input (phase B)	With test plug and disconnect switch
TB36	VB (-)		
TB37	VC (+)	Load Voltage input (phase C)	With test plug and disconnect switch
TB38	VC (-)		
	Spacer		
TB39	GROUND	Ground	
TB40	Pt100_PE	Pt100 RTD sensor common to P.E. ground	See Note 5
TB41	Pt100_S-	Pt100 RTD sensor common to measurement input	See Note 5
TB42	Pt100_S+	Pt100 RTD + wire connected to measurement input	See Note 5
TB43	GROUND	Ground	
Protective Earth (GND / PE)		Enclosure chassis to be bonded to External Ground Stud 6mm	

Note 1: if the coil voltage differs from power supply voltage a) remove the bridge TB1-TB2, then b) connect the C/B coil voltage (+) to TB2.

Note 2: if the coil voltage differs from power supply voltage a) remove the bridge TB3-TB4, then b) connect the C/B coil voltage (-) to TB4.

Note 3: CSD_Enable input in series with the Bypass switch on the STM045000's front panel (internally wired to STMVX DI4 input). Connect TB5 to TB1 (V2P) if the remote Bypass control input is not used.

Note 4: For proper operation of SynchroTeq MVX, all three 52a signals must be wired. Instal provided jumper to bridge TB8-9-10 terminals when using only 52a_A.

Note 5: for 3 wires Pt100 RTD temperature sensor type.

TERMINAL BLOCKS & SENSORS IN MV SWITCHGEAR

When practically feasible and convenient a suitable terminal block will be integrated in the controlled MV switchgear (LV compartment) for its connection to the VIZIMAX Controlled Switching Enclosure - STM045000. This terminal block shall be personalized depending on the installation settings and switchgear configuration.

Example - Control of a 3-pole (simultaneous) operated MV switchgear for energizing a power transformer:

Power sources:

- Main switchgear power supply (V2): used for powering the STM045000 cabinet
- CB coil voltage (V1), when different than V2: for monitoring and compensation purposes.

Digital I/Os:

- CSD Enable input (optional): remote control of the SynchroTeq unit's mode when the STM045000's front panel selector is on 'controlled' position.
 - o ON = SynchroTeq is 'In-service' = controlled switching
 - o OFF = SynchroTeq is 'Out-of-service' = SynchroTeq is Bypassed = random switching
 - o Connect TB5 to TB1 (or TB2 if V1=V2) if the remote control is unused.
- Close command input
- Open command input
- One (1) 52a input: CB position contact (jumper on TB8-9-10 must be installed)
- System OK output: relay output, health status. Contact closed = system OK
- One (1) Close OUT: power output, CLOSE coil driver
- One (1) Open OUT: power output, OPEN/TRIP coil driver

Measurement transformers:

- V Source - Feeder or power grid voltage:
 - o One (1) voltage measurement – Phase A only.
 - o Measurement device: magnetic PT/VT, capacitive divider, resistive divider.
 - o Dual range: traditional instrument transformer (0 to 200VAC) or Low Energy Analog "LEA/LPIT" (0 to 20VAC)
- Load Currents:
 - o Three (3) current measurements – Phases A, B, C.
 - o Current measurement can be done upstream or downstream of the C/B.
 - o 1Amp or 5Amp, from inductive current transformer cores.
- V Load - Load side/transformer voltages:
 - o Three (3) voltage measurements – Phases A, B, C.
 - o Measurement device: magnetic PT/VT, capacitive divider, resistive divider.
 - o Dual range: traditional instrument transformer (0 to 200VAC) or Low Energy Analog "LEA/LPIT" (0 to 20VAC)

Analog I/O:

- Internal switchgear temperature:
 - o Pt100 / RTD sensor – Three wires type

EXAMPLE OF TERMINAL BLOCKS & WIRING – MV SWITCHGEAR

Configuration example:

- Three (3) simultaneous pole operated (gang operated) MV switchgear
- MV switchgear with four (4) resistive dividers
- Switchgear coil voltage *matching* the main switchgear’s power supply voltage ($V1 = V2$)
- CSD ENable: control from MV switchgear.

MV Switchgear – Suggested terminal block – Installs in LV compartment

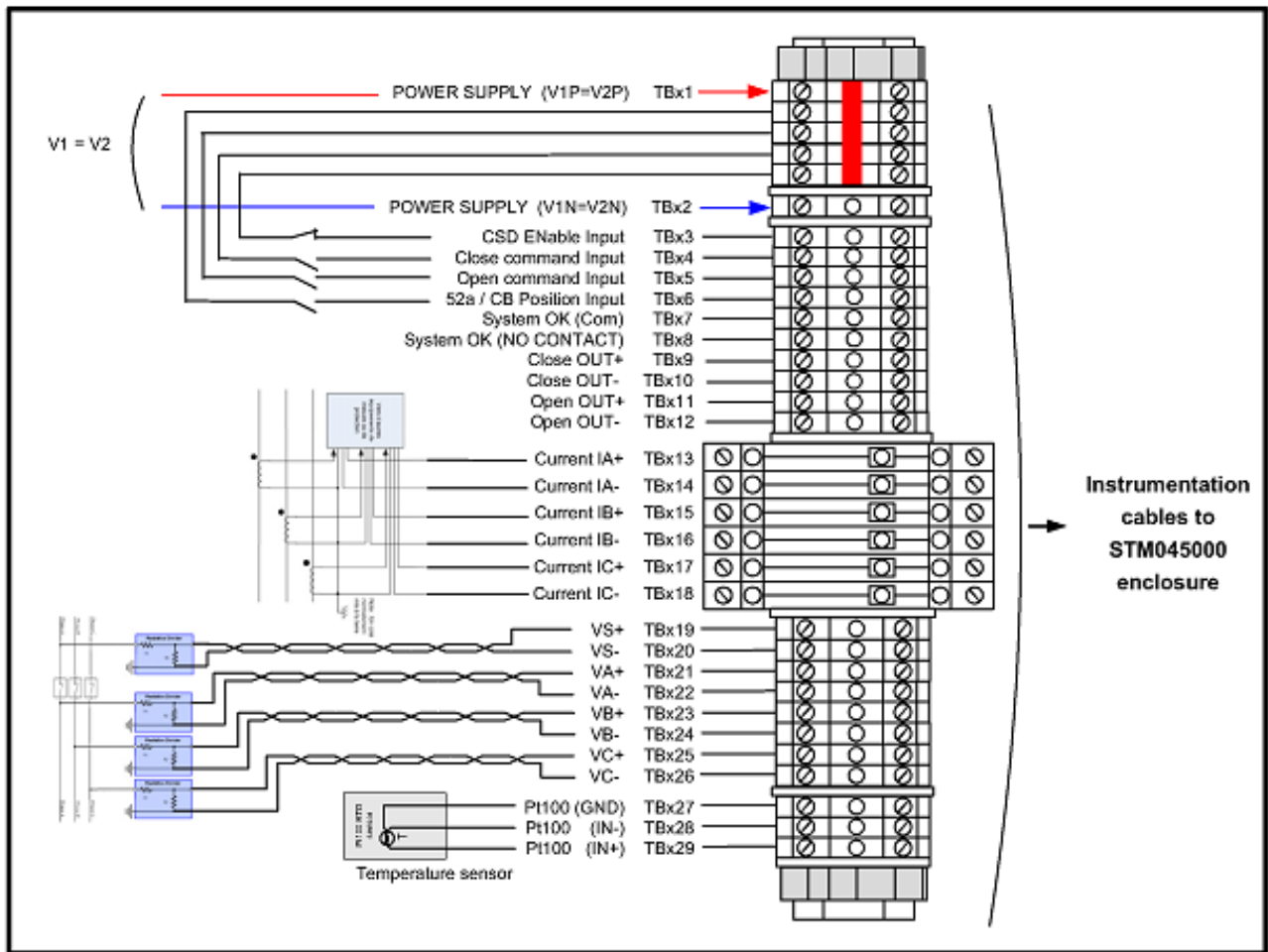

FIGURE 5 EXAMPLE OF SUGGESTED TERMINAL BLOCKS INSTALLED IN MV SWITCHGEAR

Notes:

- The PT100 RTD sensor preferably installs in the ‘breaking section’ (enclosure of the controlled C/B) in the MV switchgear.

Please refer to the STM045000 User Guide for more examples.

INSTRUMENTATION CABLES BETWEEN VIZIMAX ENCLOSURE AND SWITCHGEAR

The instrumentation cables, supplied by the customer or its electrical contractor or system integrator, are used to connect the VIZIMAX Controlled Switching Enclosure - STM045000 - to the controlled medium voltage switchgear bay.

The instrumentation cables required between the MV switchgear and the VIZIMAX Controlled Switching Enclosure are dictated by the switched load type and the internal switchgear configuration (pole operated type, voltage measurement device, coil monitoring power supply and CSD enable command).

Please refer to the STM045000 User Guide for more details.

SPECIFICATIONS

Characteristics	Value	Standards reference
Operating temperature	-40 to +70 °C	IEC 61010-1
Storage temperature	-50 to +85 °C	
Rated Power	20W max. (without option) <ul style="list-style-type: none"> - The external power supply must be able to sustain a 6A cold start current for 50ms at unit start up (See note below). - When the optional SynchroTeq Communication Module (RWK000016) is included in the enclosure, the external power supply must be sized accordingly to feed this module. 	
Maximum altitude	2000 m	
Maximum Relative humidity (R.H.)	95 % without condensation	IEC 60068-2-30
Enclosure	IP54	

NOTE:The SynchroTeq MV power supply includes a power reserve capable of sustaining a 100ms power interruption. The energy storage components may induce a 6A cold start current for 50ms at unit start up. The external power supply must be able to sustain this inrush current when energizing.

NOTE:Please refer to SynchroTeq MV datasheet for SynchroTeq MV unit specifications.

Physical dimensions	Value
Dimension (L-H-D)	500mm x 500mm x 250mm
Weight	22.7 kg (50.0 lbs)

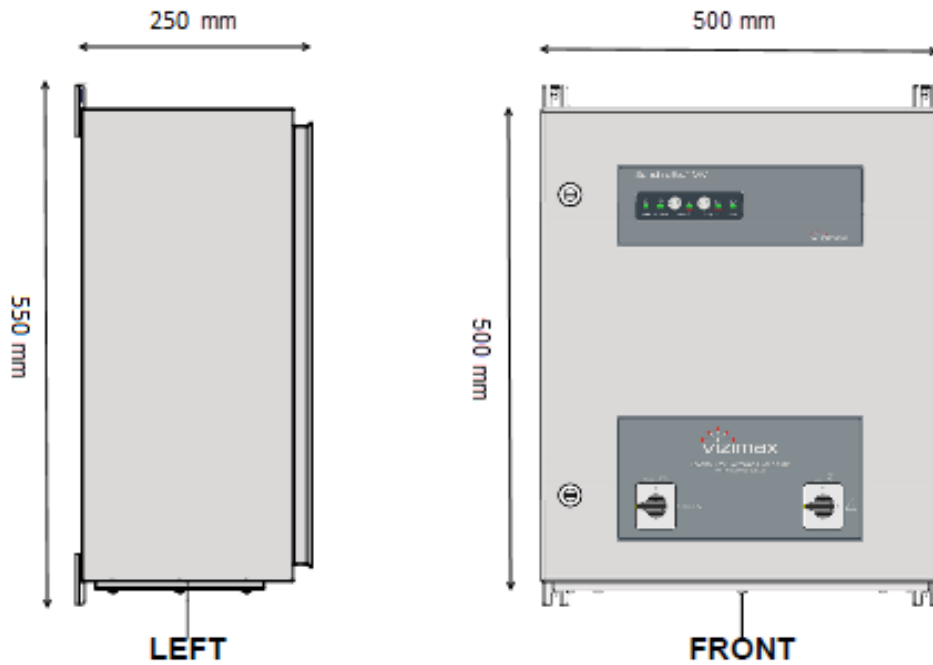

FIGURE 6 STM045000 MOUNTING POINTS AND EXTERNAL DIMENSIONS

NOTE: Please refer to STM045000 User Guide for detailed enclosure specifications.

ORDERING INFORMATION

STM045000 **Controlled Switching Enclosure:** This metal paint enclosure includes a SynchroTeq MV unit and a built-in Bypass logic, for controlled operations of MV switchgear.
Standard communication link: 100BASE-TX (copper Ethernet / RJ45 connector).
Time synchronization via NTP-SNTP time server on Ethernet, via IEEE PTP 1588 clock source on Ethernet, or via manual synchronization from a connected computer.
Native connectivity: via IEC61850 MMS Server Ed.2 protocol.

To select ordering options such as, power supply voltage, bypass configuration, IRIG-B synchronization or communication options, please refer to the ‘Smart Coding’ document ‘STM045000-SC’ available on the VIZIMAX web site <https://VIZIMAX.com>

Power supply versions:

- 24 VDC (20 VDC - 35 VDC) or
- 48 VDC (36 VDC - 72 VDC) or
- 110 VDC (70 VDC – 140 VDC) or
- 125 VDC (70 VDC - 140 VDC).

Bypass configurations:

- Magnetic contactors bypass logic or
- Passive bypass logic (with 2 diode trios)

Available options:

RWC0Y0001 –IRIG-B time-synchronization interface:

- IRIG-B000/B004 IEEE C37.118
- IRIG-B000/B004 IEEE-1344
- IRIG-B003

STAMMST00 – Media converter – 100BASE-TX to 100BASE-FX / fiber-optic interface – Fiber-optic: multimode type with ST connectors.

RWK000016 - SynchroTeq Communication Module - supporting IEC 61850 server Ed.1, Modbus slave (TCP and RTU), and DNP3 slave protocols and providing one 100BASE-TX (RJ45) and one multimode fiber optic 100BASE-FX (ST connectors) Ethernet ports, and two serial ports.

VIZIMAX also offers commissioning and training services: please inquire.

NOTE: These specifications are subject to change without prior notice.

CUSTOMER SUPPORT

Please contact us at:

Communicate by:	Details
Web	https://www.vizimax.com/support
Email (support)	support@vizimax.com
Mail	VIZIMAX Inc. 2284 Rue de la Province Longueuil, Québec Canada J4G 1G1
Telephone	+1 450-679-0003
Fax	+1 450-679-9051

NOTE: Certain charges and conditions may apply depending on the nature of the services requested.



Support contact:

support@vizimax.com
www.vizimax.com/support

VIZIMAX, the VIZIMAX logo, RightWON, WiseWON, SynchroTeq and the RightWON icons are trademarks or registered trademarks of VIZIMAX Inc. in Canada, the United States and other jurisdictions. All other trademarks, registered trademarks and service marks are the property of their respective owners.