



STANDALONE MERGING UNIT (AMU)

DATASHEET



(Panel mount configuration shown here)

MGU010000

2024-04-30

©2024 Vizimax Inc. All rights reserved

This specification is subject to change without prior notice.

TABLE OF CONTENT

PRODUCT OVERVIEW	4
VIZIMAX AMU - MAJOR FEATURES	5
HARDWARE HIGHLIGHTS	5
OPERATING ENVIRONMENT	6
TIME SYNCHRONIZATION	7
TIME SYNCHRONIZATION SERVER MODE	7
COMMUNICATION LINKS.....	8
DATA ACQUISITION RATES	9
DATA REPORTING AND OPTIONAL CONTROL.....	10
OPTIONAL 61850 GOOSE CIRCUIT BREAKER CONTROL MODEL (XCBR).....	11
TECHNICAL SPECIFICATIONS	12
<i>Compliance and Certifications</i>	<i>12</i>
<i>Type Tests</i>	<i>12</i>
<i>Temperature Test Performances</i>	<i>13</i>
POWER SUPPLY	14
<i>Power supply for standard AMU model.....</i>	<i>14</i>
CONTROL AND COMMUNICATION	15
<i>Controller.....</i>	<i>15</i>
<i>Internal Time Base and Time Synchronization.....</i>	<i>15</i>
<i>Local User Interface</i>	<i>16</i>
<i>Communication ports</i>	<i>16</i>
ANALOG MEASUREMENT.....	17
<i>Analog current measurement inputs (CT for standard AMU model).....</i>	<i>17</i>
<i>Analog voltage measurement inputs (PT for standard AMU model)</i>	<i>18</i>
DIGITAL INPUTS / OUTPUTS.....	19
<i>Digital inputs</i>	<i>19</i>
<i>Circuit breaker control Outputs (optional).....</i>	<i>20</i>
<i>Signalization digital outputs.....</i>	<i>20</i>
DATA REPORTING AND CONTROLS	21
<i>Sampled Value Reporting</i>	<i>21</i>
<i>IEC 61850-GOOSE publisher.....</i>	<i>21</i>
<i>IEC 61850-GOOSE Subscriber with XCBR Control model.....</i>	<i>22</i>
<i>IEC 61850 MMS Server Ed.2.....</i>	<i>23</i>
<i>MODBUS protocol (Slave).....</i>	<i>23</i>
MOUNTING CONFIGURATIONS	24
<i>Standard Mount (standalone)</i>	<i>24</i>

Panel Mount 26

Rack Mount 27

ABOUT THE AMU-RTS (REAL TIME SIMULATION) MODEL.....28

SPECIFICITIES FOR THE AMU-RTS PRODUCT 29

Power supply (for AMU-RTS model) 29

Digital inputs (for AMU-RTS model) 30

High current Digital Outputs (for AMU-RTS model) 30

Analog current measurement inputs (for AMU-RTS model)..... 31

Analog voltage measurement inputs (for AMU-RTS model)..... 32

ORDERING INFORMATIONS33

PRODUCT OVERVIEW

The Vizimax Standalone Merging Unit (AMU) converts analog AC current and voltage measurements into high accuracy digital messages or Sampled Values (SV) published over a substation process bus in compliance with the IEC 61850-9-2LE and IEC 61869-9 standards.

The unit provides the capability of transmitting Sampled Values (SV) according to the Protection portion of the standard or based on the Measurement portion of the standard.

The Vizimax Standalone Merging Unit can publish two IEC data streams **simultaneously**, no matter the format (example: 80 s/cycle according to IEC 61850-9-2LE + 14400 s/sec according to IEC 61869-9). Data can be directly used by bay controllers and/or protection relays that support these protocols.

The Vizimax AMU's time synchronization can be achieved via external equipment (i.e IRIG-B/PPS), or via network link (i.e PTP1588, SNTP). An optional built-in GPS Receiver allows for the AMU's time synchronization even though no other external synchronization source is available. When synchronized through PTP1588 or when equipped with its GPS Receiver the Vizimax's AMU can be a precision time synchronization server to adjacent equipment.

The AMU features multiple Ethernet communication ports that support a configurable parallel redundancy protocol (PRP), as well as the local or remote access to the unit for its operation and configuration.

The AMU supports 61850-GOOSE publisher of digital inputs and signalization outputs.

The IEC 61850-GOOSE subscriber protocol with the XCBR model is supported with the MGC001000 option (+ 6 high current - high speed outputs) to control a 3-phase circuit breaker.

The AMU supports the Modbus TCP/RTU (slave) protocol thus allowing industrial equipment and controllers to leverage its data streams.

Vizimax also offers an **AMU-RTS version** (Standalone Merging Unit for Real-Time Simulation) suitable for hardware-in-the-loop **Real-Time Simulation** environment such as OPAL-RT's RT-LAB or Hypersim, or RTDS Technologies' RTDS.

With its outstanding performances in measuring, computing and reporting time stamped data, the Vizimax Standalone Merging Unit is a perfect solution for new digital substations or for the retrofit and digitalization of legacy equipment in existing substations.

VIZIMAX AMU - MAJOR FEATURES

- Publish two IEC data streams **simultaneously**, no matter the format (IEC 61850-9-2LE and IEC 61869-9).
- Broad variety of time synchronization methods from external sources and precision clocks, either standalone or networked.
- Optional built-in GPS Receiver allowing for precision time synchronization even in the absence of external sources or clocks.
- Precision time synchronization server: synchronize other devices, IEDs, controllers when fitted with the built-in GPS Receiver or when synchronized via PTP 1588.
- IEC 61850 GOOSE Messaging Publisher.
- IEC 61850 MMS server Ed.2 (with firmware 1.5 and up).
- IEC 61850 GOOSE Messaging Subscriber (with MGC001000 option).
- Modbus TCP/RTU connectivity (slave) allowing for data sharing with industrial equipment.

HARDWARE HIGHLIGHTS

- High precision, 20-bit accuracy on current inputs and 16-bit accuracy on voltage inputs.
- CT inputs support extended dynamic range (DR) up to 160 A (for 5A range).
- 4 dry contacts relay outputs for alarm signalization.
- 10 opto-isolated digital inputs to monitor status, event or alarm conditions of other equipment.
- 6 optional high current - high speed digital outputs for circuit breaker control (option MGC001000).
- Accommodates a wide temperature range: from -40 °C up to +85 °C.
- Local HMI and secured web-based configuration and operation interface.

OPERATING ENVIRONMENT

The Vizimax AMU combines the acquisition of AC current and voltage measurements from conventional transformers (CTs and PTs) and converts these signals into digital time-synchronized sampled values.

The Vizimax AMU can be installed in a substation control room or integrated in an outdoor equipment junction box.

In its operating environment, the AMU device is connected to several components or systems:

- The DC power supply
- The AC measurement input connections (from CTs and PTs)
- The time synchronization inputs
- The communication links (Ethernet links, Ethernet service port and serial port).
- The status and alarm signals (signalization outputs and digital inputs).
- 6x optional high current - high speed digital outputs (MGC001000) to control a circuit breaker (XCBR function).

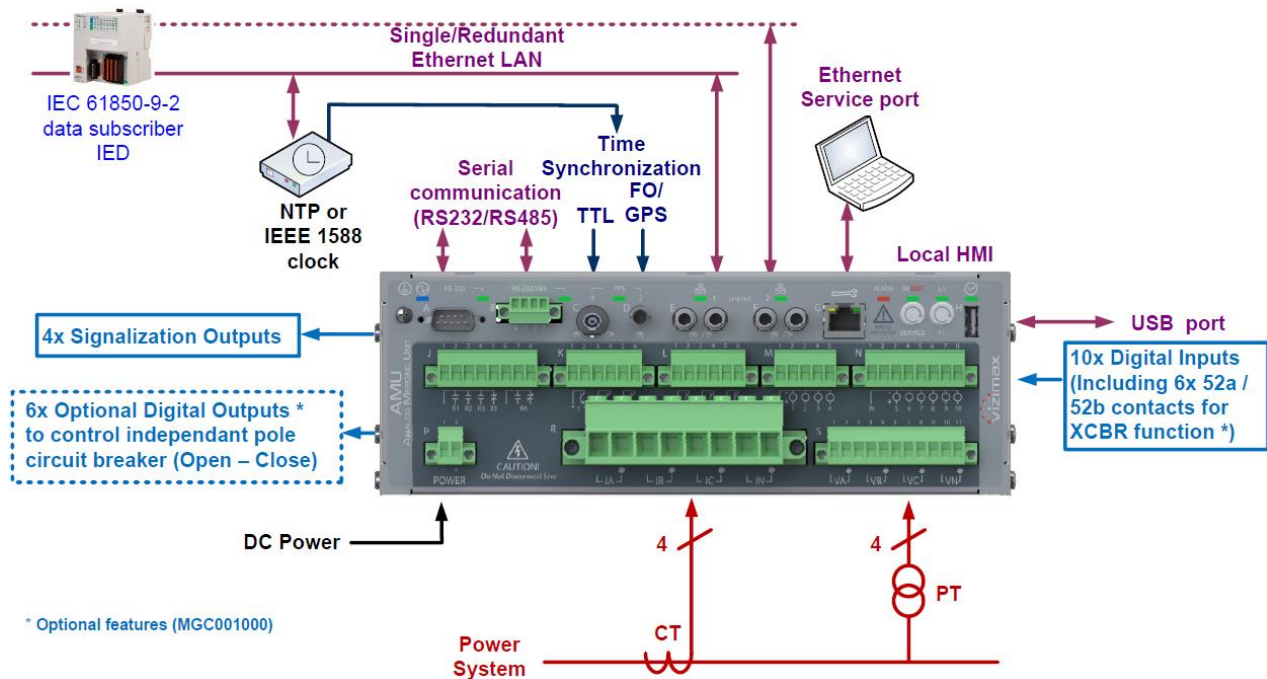

FIGURE 1 AMU IN ITS OPERATING ENVIRONMENT

The VIZIMAX AMU has a capability of publishing the signalization output states and the digital IOs states using IEC 61850-GOOSE publisher protocol. This functionality allows fast data exchange with protection systems and automation platforms.

The MGC001000 option allows for controlling a 3-phase circuit breaker (independent poles) with the 6 power outputs by subscribing to GOOSE messaging.

TIME SYNCHRONIZATION

Vizimax AMU's time synchronization can be achieved by either:

- **An external device:**
 - IRIG-B un-modulated signal:
 - IRIG-B000/B004 C37.118
 - IRIG-B000/B004 IEEE1344
 - IRIG-B signal received through either:
 - fiber optic – ST connector
 - copper – BNC-TTL
- **A network link:**
 - IEC 61588 (IEEE 1588) PTP compliant master clock: Ethernet port 1 and 2 include specific hardware for a full PTP1588 compatibility (multiple profiles incl. IEC 61850-9-3).
 - SNTP Client – Server service enhanced with BNC-TTL or IR fiber PPS inputs
- **In Stand-alone:**
 - By using the optional built-in GPS receiver (Option MGC000100).

Any one of these approaches renders the required accuracy to transmit SVs (sampled Value) in conformance with the IEC 61869-9 and IEC 61850-9-2LE protocols.

TIME SYNCHRONIZATION SERVER MODE

Vizimax AMU has the capability of providing time synchronization source to other equipment:

- PTP1588 time synchronization server (master clock with leap second support): requires the optional built-in GPS receiver or a connection to another PTP1588 time synchronization source.
- NTP time synchronization server (UTC format support): requires the optional built-in GPS receiver or a connection to another time synchronization source providing UTC time data.
- High accuracy PPS output signal available to other devices via the BNC connector (when not used as an input).

COMMUNICATION LINKS

The AMU provides 3 Ethernet ports:

- Port 1 and 2 can be configured for 61850-9-2 / 61869-9 communications, GOOSE messaging as well as for time synchronization and secured access to a web interface and configuration tools:
 - Standard: Copper Ethernet connections (100BASE-T) with RJ-45 connectors
 - Option MGC010000: Replace 2xRJ45 by 2x Fiber-optic connections 100BASE-FX with ST connectors multimode (allowing 2km transmission)
 - Option MGC020000: Replace 2xRJ45 by 2x Fiber-optic connections 100BASE-LX with LC connectors Single mode (allowing 10km transmission)
 - Option MGC021000: Replace 2xRJ45 by 2x Fiber-optic connections 100BASE-FX with LC connectors multimode (allowing 2km transmission)
- Port 3 located on the AMU's back panel (or front panel in the 19" rack configuration) is used as a local service port or for remote maintenance (RJ-45 connector).

The AMU provides 2 serial ports:

- The RS232 port A.
- The RS485-RS232 configurable port B.

The AMU offers a user-friendly graphical web operating interface. Furthermore, the Vizimax Tool Suite for Microsoft Windows provides a rich environment for the remote configuration of the unit and data analysis.

DATA ACQUISITION RATES

The AMU publishes sampled values according to the multicast sampled values control block (MSVCB01 for protection portion of the standard) or (MSVCB02 for the measurement portion of the standard) as defined in the 9-2LE guide.

When targeting protection relays and bay controllers, sampling occurs 80 times per cycle (thus 4000 or 4800 times per second depending on nominal network frequency, i.e. 50 Hz or 60 Hz). When the measurement sampling is selected, the unit samples at a rate of 256 samples per cycle (12800 sample/s to 15360 sample/s) and transmits this information in blocks of 8 per the standard to minimize bandwidth usage.

The AMU also supports (MSVCB03 for protection portion of the standard) or (MSVCB04 for the measurement portion of the standard) as defined in the IEC 61869-9 standard. The advantage of this standard is to have a fixed number of sampled values per second whatever the network frequency.

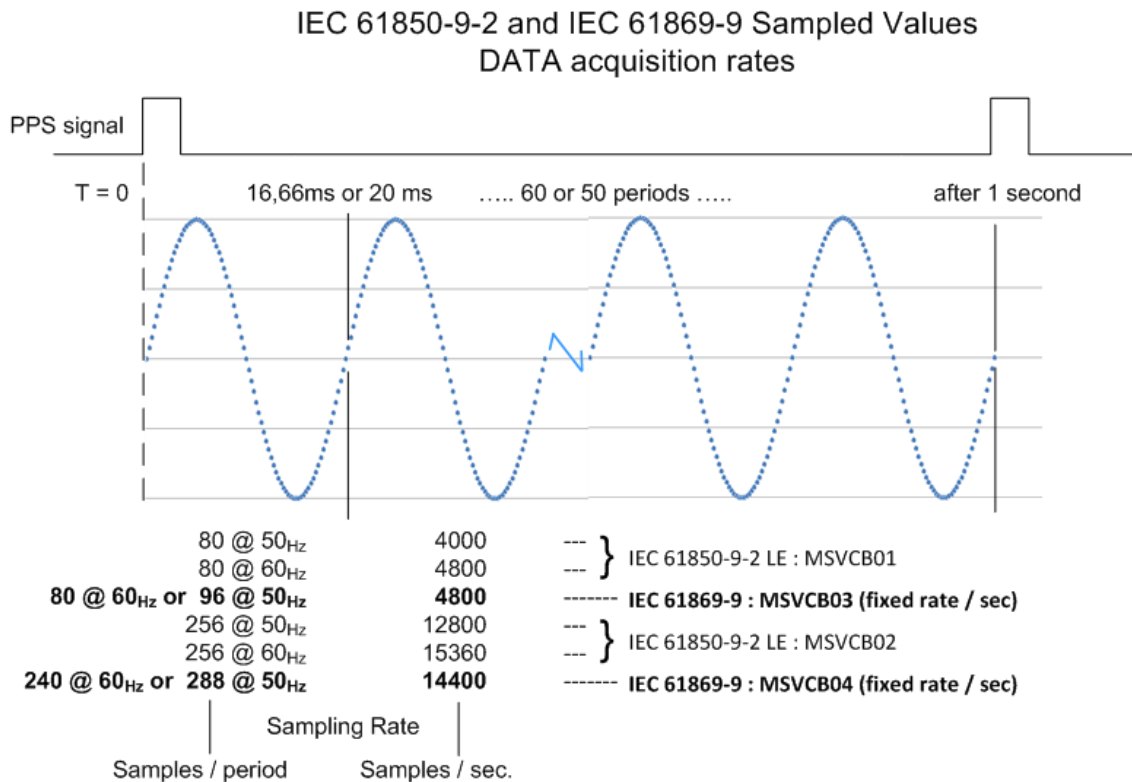

FIGURE 2 AMU DATA ACQUISITION RATES

Vizimax Standalone Merging Unit supports ALL these sampling rates and can publish two data streams simultaneously, no matter the format.

DATA REPORTING AND OPTIONAL CONTROL

Data published through IEC 61869-9 or IEC 61850-9-2LE and 61850-GOOSE formats are time stamped with accuracy better than 1ms and can be used for real time applications as well as for offline analysis.

Digital signal states can be reported over the Modbus protocol to other industrial equipment.

The secured Web interface displays an extensive set of information as described in Figure 3 below.

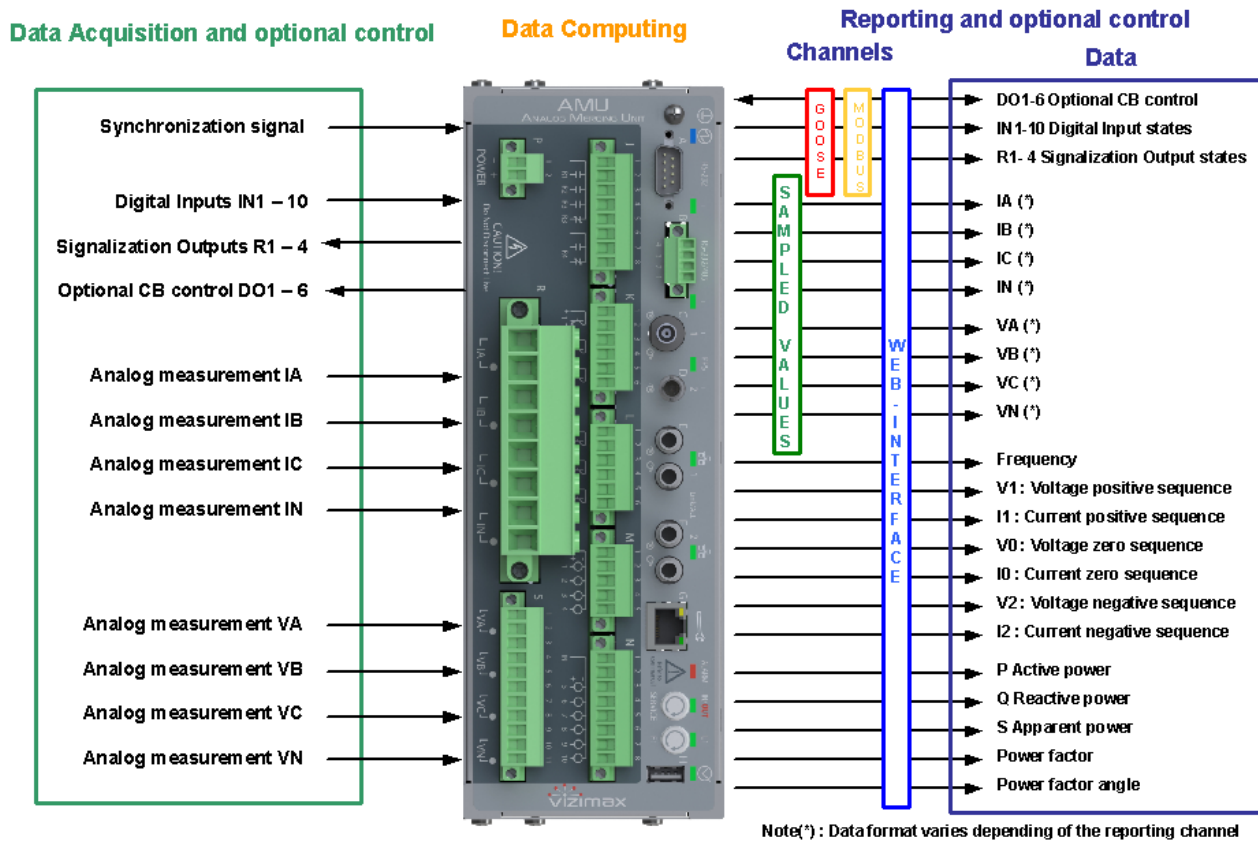

FIGURE 3 DATA ACQUISITION – REPORTING AND OPTIONAL CONTROL

Note 1: Starting firmware 1.4 and up, Vizimax unit delivered with the MGC001000 option (adding 6 high current - high speed outputs) support the GOOSE subscriber protocol with the XCBR model, allowing controlling a 3-phase circuit breaker (independent poles).

These 6 outputs can also be controlled through Modbus protocol when not activating the XCBR control model.

Note 2: Starting firmware 1.5 and up, AMU unit supports the MMS server Ed.2 protocol.

OPTIONAL 61850 GOOSE CIRCUIT BREAKER CONTROL MODEL (XCBR)

Starting firmware 1.4 and up, Vizimax unit delivered with the MGC001000 option (adding 6 high current - high speed outputs) support the GOOSE subscriber protocol with the XCBR model described in Figure 4 below.

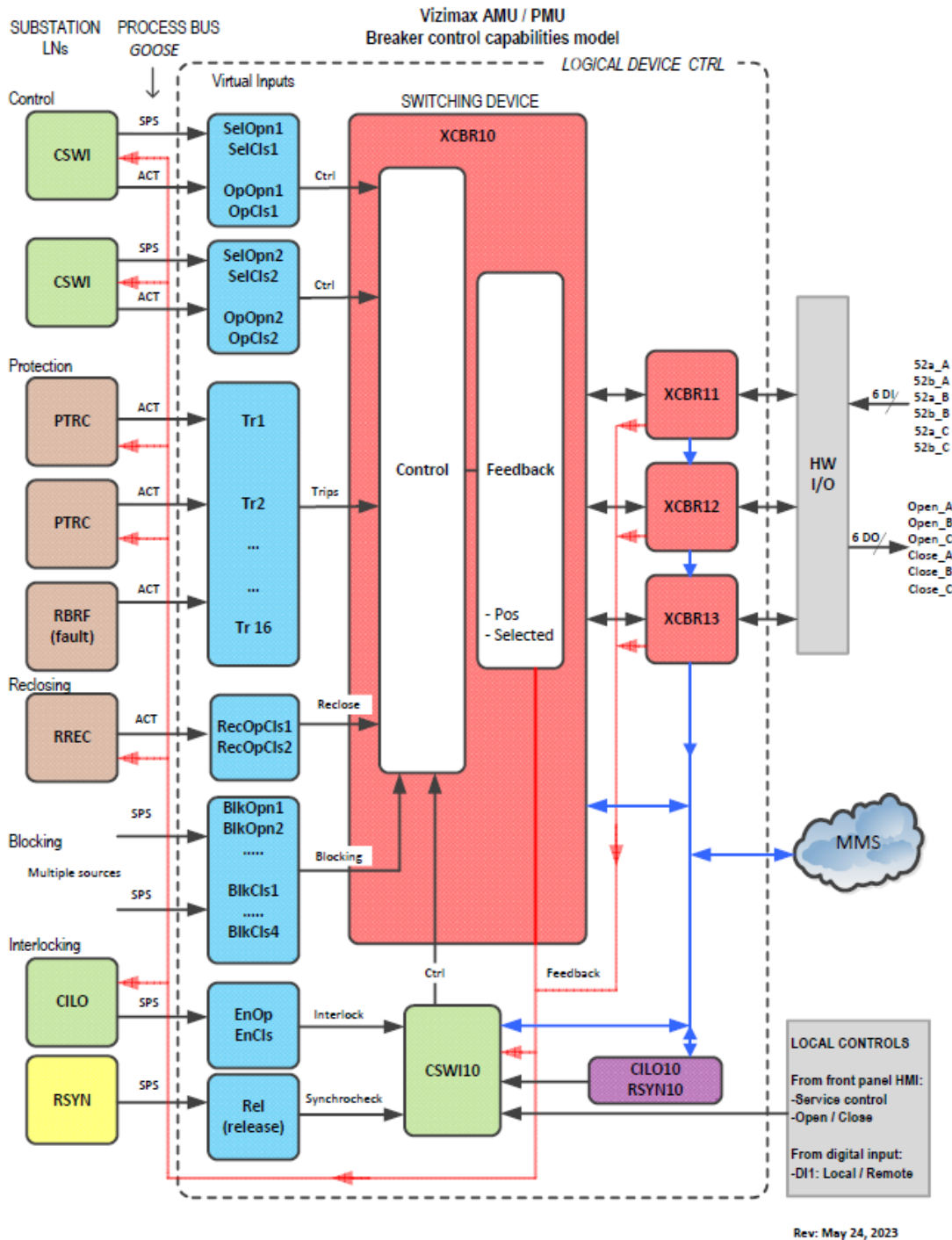

FIGURE 4 AMU 61850 GOOSE SUBSCRIBER XCBR CAPABILITIES MODEL

TECHNICAL SPECIFICATIONS

COMPLIANCE AND CERTIFICATIONS



TYPE TESTS

Type Tests		Standard	Value
Temperature range	Operating temperature		-40°C to +85°C (*see note)
	Storage temperature		-50°C to +85°C
Maximum Relative humidity (R.H.)		IEC 60068-2-30	95% without condensation
Maximum altitude		IEC 61010-1	2000 m
IP rating		IEC 60529	IP30
Normal environmental conditions		IEC 60255-1 IEC 60947-1	- No significant air pollution - Pollution degree 2
Mechanical resistance to vibrations	Performance	IEC 60255-21-1, 21-2, 21-3	Class 2
	Endurance	IEC 60255-21-1, 21-2, 21-3	Class 1
Dielectric withstand	AC inputs and I/Os	IEC 60255-5	2200 V ac, 1 s
	Communication	IEC 60255-5	1650 V ac, 1 s
Impulse voltage withstand		IEC 60255-5	5 kV
Electrostatic discharge (ESD)	Air discharge	IEC 61000-4-2	15 kV
	Direct contact discharge	IEC 61000-4-2	8 kV
Surge Immunity test		IEC 61000-4-5	Level 4
Damped oscillatory wave (1 MHz burst)	Common mode	IEC 60255-22-1	2.5 kV
	Differential mode	IEC 60255-22-1	1.0 kV
Fast transients (bursts)		IEC 60255-22-4	Level 4

Type Tests	Standard	Value
RF immunity	IEC 61000-4-3	20 V/m, from 80 MHz to 1 GHz
	IEC 60255-26	Spot frequency: 80 MHz to 2150 MHz
	ANSI/IEEE 1613	10 V/m, from 1.4 GHz to 2.7 GHz
	SN62. 1008-1	3 V/m, from 5.15 GHz to 5.75 GHz
Conducted disturbance immunity	IEC 61000-4-6	150 kHz to 80 MHz
RF emissions	CISPR 11, CISPR 22, FCC	Class A
Safety	IEC 61010-1, 3 rd edition ISO 14971: 2012	Equipment for measurement, control, and laboratory use

*Internal operating temperature; please refer to 'Temperature Test Performances' table below for more details.

TEMPERATURE TEST PERFORMANCES

Type Tests		Standard	Value
Temperature Type testing	Cold	IEC 60068-2-1	-40°C (16 hours) after cold start at -50°C
	Dry heat	IEC 60068-2-2	+70°C (16 hours)
	Damp heat cyclic	IEC 60068-2-30	+55°C at 95% R.H. (144 hours)
	UL Safety	IEC 61010-1	-40°C to +70°C

POWER SUPPLY

POWER SUPPLY FOR STANDARD AMU MODEL

The power supply is set in factory according to the ordering option.

Parameter	Value
Power supply rating (48 V)	36 V dc - 72 V dc
Power supply rating (125 V)	90 V dc - 140 V dc
Power supply rating (220 V)	180 V dc - 280 V dc
Rated power	29 W max. (typical 18 W, 0.14 A @ 125 V dc)
Connector	Phoenix MSTB 5.08 mm
Isolation	3000 V during 1 s
Fuse	Time delay, 2 x 2 A (not user serviceable)
Maximum Voltage interrupt	100 ms @ 100%

NOTE: This table is applicable to AMU standard model only.

CONTROL AND COMMUNICATION

CONTROLLER

Parameter	Value
Main processor	32-bit, 800 MHz multi-core A9 high performance ARM processor
OS	Linux
Memory	512 MB Flash memory /512 MB RAM
Real time clock	Autonomy is 36 hours without power (no battery required)
I/O board controller	32 bits, 168 MHz ARM processor with RTOS. 16 bits ADC.

INTERNAL TIME BASE AND TIME SYNCHRONIZATION

Parameter	Value
Base precision	Better than 100 nanoseconds, after 15 minutes warm-up
Time for a drift of 1.0 μ s on external time base lost	Typical: \approx 1200 s Guaranteed: 400 s @ 25°C no movement, after 15 minutes warm-up
Ethernet – SNTP (Client & Server)	RJ45, Fiber ST or Fiber LC Base precision \leq 1 millisecond
Ethernet - IEEE PTP 1588	RJ45, Fiber ST or Fiber LC Base precision \leq 25 nanoseconds
IRIG-B un-modulated or PPS-in over fiber optic	ST type frequency range: 820-850 nanometers Base precision \leq 75 nanoseconds
IRIG-B un-modulated or PPS-in over BNC	Zin: 500 Ω /50 Ω selectable by software Level: 3.3 V dc to 5.0 V dc Base precision \leq 85 nanoseconds
PPS-out over BNC	Zout: 10 Ω Vout: 5.0 V dc, Iout max = 100 mA
Built-in GPS option (*)	GPS option replaces PPS fiber optic input with a SMA antenna connector. Base precision \leq 45 nanoseconds

NOTE: (*) GPS antenna and accessories are not included in the Built-in GPS receiver option.

LOCAL USER INTERFACE

Parameter	Value	
Two push buttons (back side and front side)	<ul style="list-style-type: none"> - In/Out of service - C/B Open / Close (when XCBR control is activated) 	
Ten LED (back side)	Service, alarm (2x), communication activity (3x), time synchronization, system status, C/B position and power	
Five LED (front side)	Service, alarm, system status, C/B position and power	
USB port	Interface compatibility	2.0
	Maximum speed	480 Mbit/s
	Connector type	Type A
	Voltage isolation level	N/A

COMMUNICATION PORTS

Port	Characteristic	Value
Ethernet – LAN-1	Interface	10/100 Mbps
	Connector	RJ-45, ST or LC (for fiber connection)
	Isolation	1500 VRMS
	Connector name	Port 1
	Function	User communication link
Ethernet – LAN-2	Interface	10/100 Mbps
	Connector	RJ-45, ST or LC (for fiber connection)
	Isolation	1500 VRMS
	Connector name	Port 2
	Function	User communication link
Ethernet – Service (back)	Interface	10/100 Mbps
	Connector	RJ-45
	Isolation	1500 VRMS
	Connector name	Port service–initial unit configuration and setup
	Function	Service port
RS-232 serial	Connector	DB-9
	Bit rate	115 Kbps
	Function	Console port, service operations
RS232 or RS-485 isolated serial	Connector	Phoenix type, 3.81 mm secured by screws
	Bit rate	38.4 Kbps
	Mode	Two wires interface (A-B) with jumper selectable 120 Ω terminations. Reference wire (0V) provided for high-common-mode voltage capability
	Isolation	2000 VRMS
	Function	(Reserved for internal use)

ANALOG MEASUREMENT

ANALOG CURRENT MEASUREMENT INPUTS (CT FOR STANDARD AMU MODEL)

Parameter	Value	
Number of inputs	4	
Name	IA, IB, IC and IN	
Connector type	Phoenix PC-6, 10.16mm, pluggable screw type AWG 7-18 (10.5 mm ² – 0.75 mm ²)	
Current	Rated current	1 A or 5 A, manufacturing selectable
	Saturation current	160 A @ 5 A range / 40 A @ 1 A range
	Maximum current	500 A @ 1.0 s, 160 A @ 10.0 s, 42 A @ 100.0 s 20 A continuous
Measurement category	MEAS CAT IV	
Maximum Burden @ rated current	0.01 VA @ 1 A 0.1 VA @ 5 A 4 VA @ 42 A	
Isolation	3000 VRMS	
Measurement accuracy with 100% asymmetrical current	Typical: 98% Guaranteed: 95%	
Nominal frequency range	40 Hz to 70 Hz	
Measurement bandwidth (-3 dB)	DC to 3 kHz	
Sampling frequency	19200/s	
Conversion resolution	20 bits	
CT angle compensation parameter	±1.00 degree	
CT magnitude compensation factor	x0.01 to x1000	
Hardware Accuracy 5 A or 1A range	Typical: ±0.03% @ 25 °C + (±6PPM/°C) ≤14 A (5A) or ≤3.5 A (1A) Guaranteed: ±0.1% @ 25 °C + (± 20PPM/ °C) ≤14 A (5A) or ≤3.5 A (1A) ±0.5 to 0.8% @ 25 °C + (± 125PPM/ °C) >14 A (5A) or >3.5 A (1A) after 15 minutes warm-up	

NOTE: This table is applicable to AMU standard model only.

ANALOG VOLTAGE MEASUREMENT INPUTS (PT FOR STANDARD AMU MODEL)

Parameter	Value
Number of inputs	4
Name	VA, VB, VC and VN
Connector type	Phoenix MSTB 5.08 mm, pluggable screw type AWG 13-24 (2.5 mm ² – 0.2 mm ²)
Rated voltage	57.7 V ac to 138.6 V ac (L-N)
Saturation Voltage	220 V ac
Thermal capacity	220 V ac @ continuous
Measurement category	MEAS CAT IV (0 – 150 V ac) MEAS CAT III (150 – 300 V ac)
Maximum Burden	0.05 VA
Isolation	3000 VRMS
Nominal frequency range	40 Hz to 70 Hz
Measurement bandwidth (-3 dB)	DC to 3 kHz
Sampling frequency	19200/s
Conversion resolution	16 bits
PT angle compensation parameter	±1.00 degree
PT magnitude compensation factor	x0.01 to x1000
Hardware Accuracy	Typical: ±0.05% @ 25°C + (±10 PPM/ °C) Guaranteed: ±0.1% @ 25 °C + (±15 PPM/ °C) after 15 minutes warm-up and above 20 V ac

NOTE: This table is applicable to AMU standard model only.

DIGITAL INPUTS / OUTPUTS

DIGITAL INPUTS

The AMU offers 10 digital inputs split in 2 groups, one of 6 inputs with one common and a group of 4 with their own common.

When the optional 61850 circuit breaker control (XCBR) is enabled, the group of 6 DI (connector N) is used to report the C/B position contacts (52a and 52b) for each 3 phases.

Parameter	Value
Name	DI1 to DI10
Number of inputs	10 (4 on connector M + 6 on connector N)
Maximum input voltage (48V power supply)	72 V dc, (detection threshold 28 V dc)
Maximum input voltage (125V power supply)	140 V dc, (detection threshold 80 V dc)
Maximum input voltage (220V power supply)	280 V dc, (detection threshold 150 V dc)
Isolation	Opto-coupler, 2000 VRMS
Measuring Category	MEAS CAT IV
Burden	2 mA to 5 mA
Maximum Hardware Response Time	0.10 ms at nominal voltage 1.00 ms at 80% of nominal voltage
Software Filter	Programmable, 1 ms increments up to 250ms. Advanced chatter filter
Connector	Phoenix MSTB 5.08mm, pluggable screw type.

NOTE: This table is applicable to AMU standard model only.

CIRCUIT BREAKER CONTROL OUTPUTS (OPTIONAL)

The AMU option MGC001000 offers 6 optional high speed - high current digital outputs including the 61850 GOOSE subscriber protocol. (This option is included in the PMU-RTS model).

Parameter	Value
Name	Out1 to Out6
Number of outputs	6 (3 on connector K + 3 on connector L)
Output driver technology	Solid State, independent, sourcing or sinking outputs
Rated voltage	10 V dc -280 V dc
DC rated Output current	5 A dc continuous, 22 A for 1s, 35 A for 200 ms, 70 A pulsed 10 ms
Maximum breaking current	7A @ L/R=40ms
Isolation	2000 VRMS
Switching Frequency	Up to 20Hz (with 100 kΩ load) Up to 250Hz (with current load >1A)
Maximum time from GOOSE trip message	1 ms
Over Voltage Category	OVC CAT III
Connector	Phoenix MSTB 5.08mm, pluggable screw type

SIGNALIZATION DIGITAL OUTPUTS

The AMU has 4 signaling dry contact (relay) outputs. These outputs allow the unit to send alarm conditions to other IEDs such as RTUs and annunciators.

Parameter	Value
Number of outputs	R1 to R4 2x form A and 2x form C dry contact outputs (1 form C reserved for system health status)
Function	System health, synchronization, In/Out of service, alarm.
Type	Electromechanical relays
Maximum steady AC current	3.0 A at 250 V ac
Maximum steady DC current	2.0 A at 250 V dc
Contact ratings	250 V ac, 300 V dc
Contact breaking capacity	10 A at 250 V ac 8 A @ 30 V, 0.5 A @ 125 V, 0.3 A at 250 V dc
Isolation	5000 VRMS (coil to contacts)
Over voltage category	OVC CAT III
Connector	Phoenix MSTB 5.08 mm, pluggable screw type

DATA REPORTING AND CONTROLS

SAMPLED VALUE REPORTING

Specifications	Value
2x Ethernet connections	Copper or Fiber Optic (PRP supported)
2x clients IP transport	TCP/UDP or UDP spontaneous
Digital Interface Message format	IEC 61850-9-2LE - MSVCB01 (protection) and MSVCB02 (measure) IEC 61869-9 - MSVCB03 (protection) and MSVCB04 (measure) Two data streams can be published <u>simultaneously</u> no matter the format.
Data published in MSVCB	Voltage: VA, VB, VC and VN Current: IA, IB, IC and IN (Sample Timestamp and Time quality implicitly included in MSVCB.)

NOTE: Additional measured and computed data such as active, reactive and apparent power or symmetrical components (zero, positive and negative sequences) are displayed on the web interface.

IEC 61850-GOOSE PUBLISHER

Parameter	Value
Communication links	Ethernet1 - Ethernet2 - Redundant
Message format	IEC 61850-GOOSE Ed2
Publishing rate	Configurable by software for each block independently
DataSet published in GOOSE Control Block	<p>GOOSE Control Block 01 (gcb01) Dataset: TxGOOSE_PhysIOs Dedicated to the Physical IOs: Digital inputs (DI1 – DI10), Digital outputs (Out1 to Out6), Digital relay outputs (R1 to R4)</p> <p>GOOSE Control Block 02 (gcb02) Dataset: TxGOOSE_CB1 Dedicated to the XCBR10 GOOSE Control Block</p> <p>GOOSE Control Block 03 (gcb03) Dataset: TxGOOSE_CB1Pos Dedicated to the circuit-breaker XCBR10 position</p> <p>(Timestamp and Time quality are implicitly attached with all input/output state change in GOOSE data frame).</p>

NOTE: The AMU .icd file defining the complete device capability following the IEC 61850 standard is provided in the documentation folder of the Vizimax Tool Suite.

IEC 61850-GOOSE SUBSCRIBER WITH XCBR CONTROL MODEL

Starting firmware 1.4 and up, Vizimax unit delivered with the MGC001000 option (adding 6 high current - high speed outputs) support the GOOSE subscriber protocol with the XCBR model, allowing controlling a 3-phase circuit breaker (independent poles).

Parameter	Value
Communication links	Ethernet1 - Ethernet2 - Redundant
Message format	IEC 61850-GOOSE Ed2
GOOSE Subscribers	Up to 32 GOOSE subscribers
Publishing rate	Configurable by software for each block independently
Virtual Inputs	Virtual inputs Control: 8 inputs (select+operate for open and close, from 2 sources) Protection: 16 trip inputs Reclosing: 2 inputs Blocking: 6 inputs (2 opening and 4 closing) Interlocking: 3 inputs (including 1 input for Synchrocheck)
XCBR Control	XCBR10 Control mode: None (Outputs are not controlled by XCBR) Independent single pole operated (IPO) Simultaneous three Pole operated (Gang operated) Control model: Status only Direct operate (with normal or enhance security) SBO (with normal or enhance security) XCBR11-12-13 Status only
Internal CSWI Control	CSWI10 Control model: Status only Direct operate (with normal or enhance security) SBO (with normal or enhance security)

NOTE: The AMU .icd file defining the complete device capability following the IEC 61850 standard is provided in the documentation folder of the Vizimax Tool Suite.

IEC 61850 MMS SERVER Ed.2

Starting firmware 1.5 and up, Vizimax AMU supports the MMS server protocol:

Protocol	Characteristics
IEC 61850 MMS Server Ed.2	<ul style="list-style-type: none"> - XCBR control - Full dataset refreshed every second - 6 predefined reports (3 unbuffered + 3 buffered)

MODBUS PROTOCOL (SLAVE)

Vizimax AMU unit integrates the Modbus slave protocol over either:

- A serial link RS232-RS485 (Modbus-RTU)
- A TCP/IP link (Modbus-TCP).

Parameter	Value
Modbus functions	01: Read Coil Status: Discrete Output Coils (see note) 02: Read Input status : Discrete Inputs/Outputs 04: Read Input Registers: Analog Input Registers 05: Force (write) Single Coil : Discrete Output Coils (see note) Note : Only when MGC001000 option is present
Modbus-TCP	TCP/IP over Ethernet port 1 or 2 User port configurable 1 to 65535 (default port number: 502 as reserved in Modbus-TCP protocol). Up to 5 simultaneous connections Output control available when MGC001000 option is present
Modbus-RTU	Over RS232 or RS485 Serial port B 300 to 115200 Baud rate Data Bits: 8, No Parity, 1 Stop bit. Slave address: 1 to 247 Output control available (only when MGC001000 option is present)
Modbus Data Format	Value format: Integer or float Configurable 32-bits words ordering
Data Register Mapping	Refer to the mapping tables.

Please refer to the AMU support documents for details on the Modbus mapping tables.

NOTE: Modbus output control function is disabled when IEC 61850 XCBR control is enabled.

MOUNTING CONFIGURATIONS

The Vizimax Standalone Merging Unit is available in 3 mounting configurations: standard (stand-alone), panel mount (with a 12" front panel) or a 19" rack mount.

TABLE 1 PHYSICAL DIMENSIONS

Specifications	Value
Width	257 mm/10.125 in for standard mount 305 mm/12 in for panel mount 483 mm/19 in for Rack mount
Height	92 mm/3.6 in for standard mount 105 mm/4.1 in for panel mount 3U: 132.56 mm/5.219 in for Rack mount installation
Depth	134 mm/5.25in
Weight	Standard mount 3.0 kg (6.6 lbs) Panel mount 3.3 kg (7.3 lbs) Rack mount 3.6 kg (8 lbs)

STANDARD MOUNT (STANDALONE)

The AMU standard mount is a breeze to install. It can be mounted directly inside an equipment control enclosure (Indoor or outdoor). It also includes movable mounting brackets for multiple mounting positions (horizontal or vertical).



FIGURE 5 STANDARD CONFIGURATION (STANDALONE)

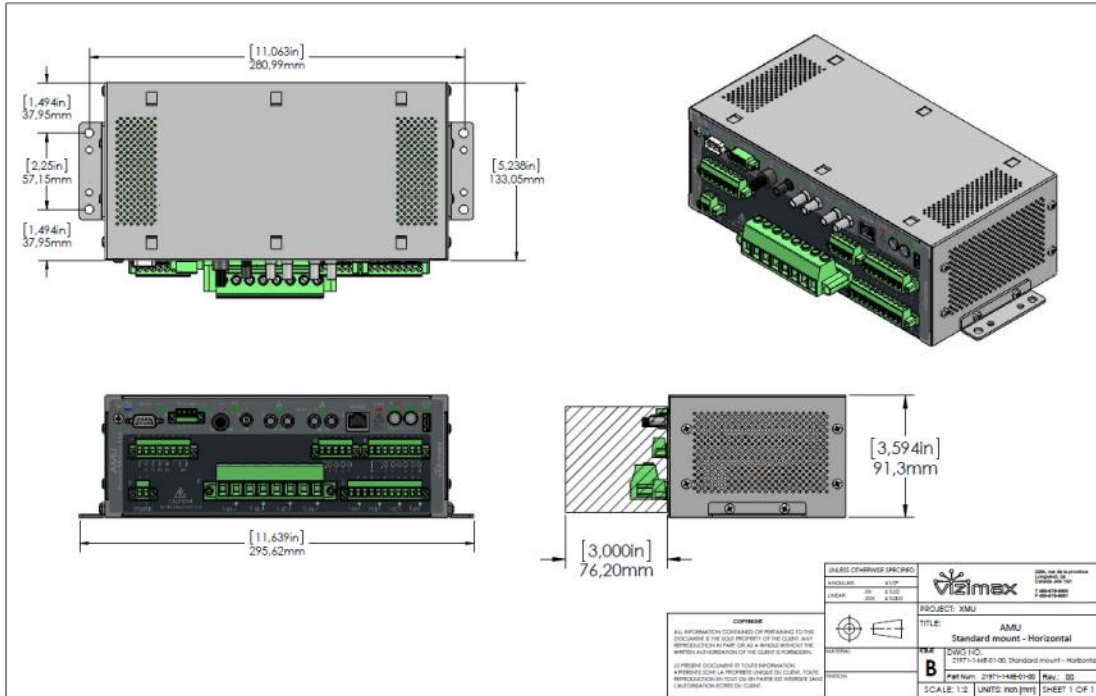

FIGURE 6 STANDARD CONFIGURATION —HORIZONTAL

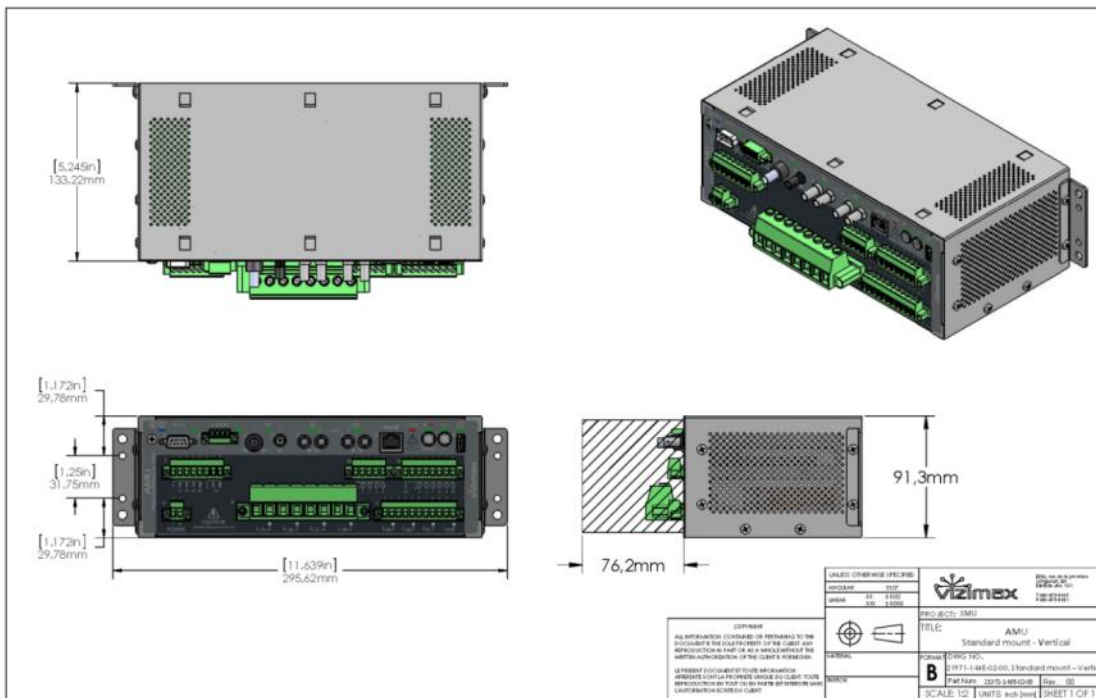

FIGURE 7 STANDARD CONFIGURATION —VERTICAL

PANEL MOUNT

The AMU panel mount is used for mounting the AMU on a metallic panel or swing door of an enclosure. It includes mounting specific brackets. The panel face plate is 104.14 x 304.8 mm (4.1 x 12.0 in).

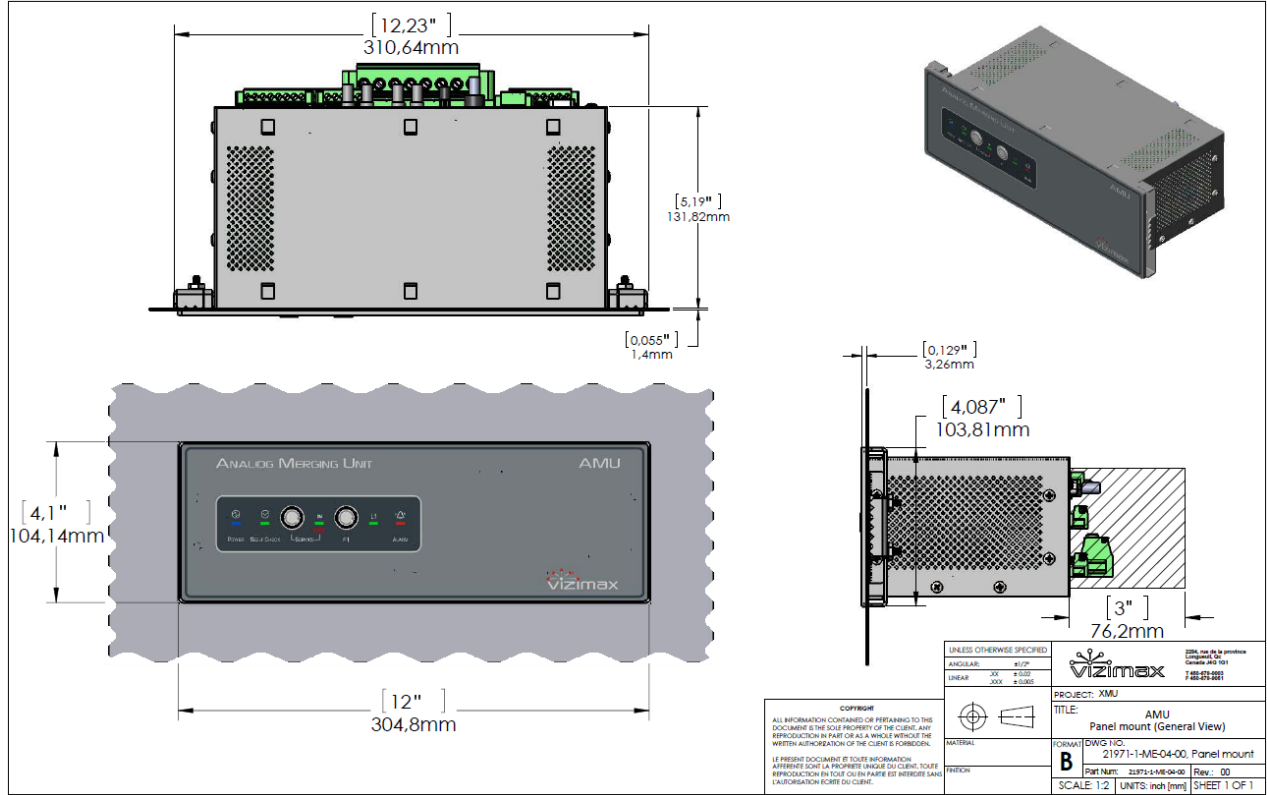

FIGURE 8 PANEL MOUNT CONFIGURATION

RACK MOUNT

The AMU rack mount is installed on an EIA 19 in rack (482.6 mm) in the substation control building. Panel size: 3U standard panel (5.219 in x 19 in).

In the configuration the Ethernet service port is relocated on the front panel.

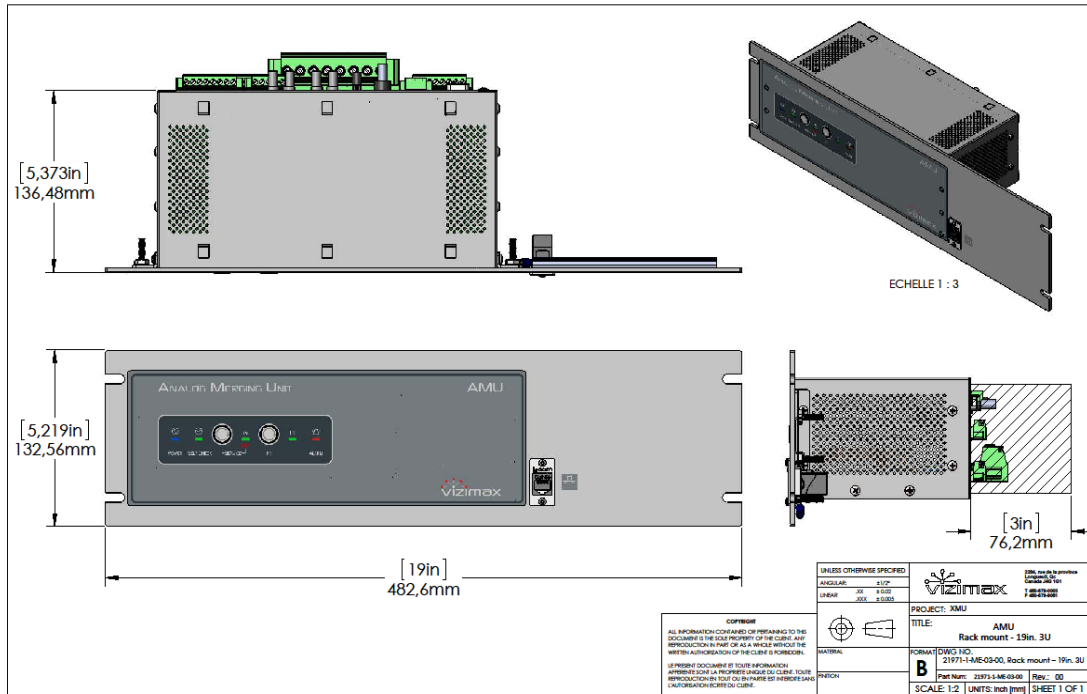

FIGURE 9 19" RACK MOUNT CONFIGURATION

A DIN rail (120 mm - 4.8 in) - is provided on the rear panel to mount terminal blocks or IED accessories.

ABOUT THE AMU-RTS (REAL TIME SIMULATION) MODEL

The **AMU-RTS** (Standalone Merging Unit for Real-Time Simulation) is a component of the AMU product family specially designed for hardware-in-the-loop **Real-Time Simulation** environment such as OPAL-RT's RT-LAB™ or Hypersim™, or RTDS Technologies' RTDS®

The AMU-RTS unit offers the same functionality as the standard AMU, but the AC measuring inputs (current and voltage inputs) are compatible with a low voltage signal (10Vrms) provided by real-time simulation hardware.

Therefore, real life AMU's applications can be fully simulated in a laboratory environment without needing expensive analog power amplifiers or high voltage discrete I/O interfaces.

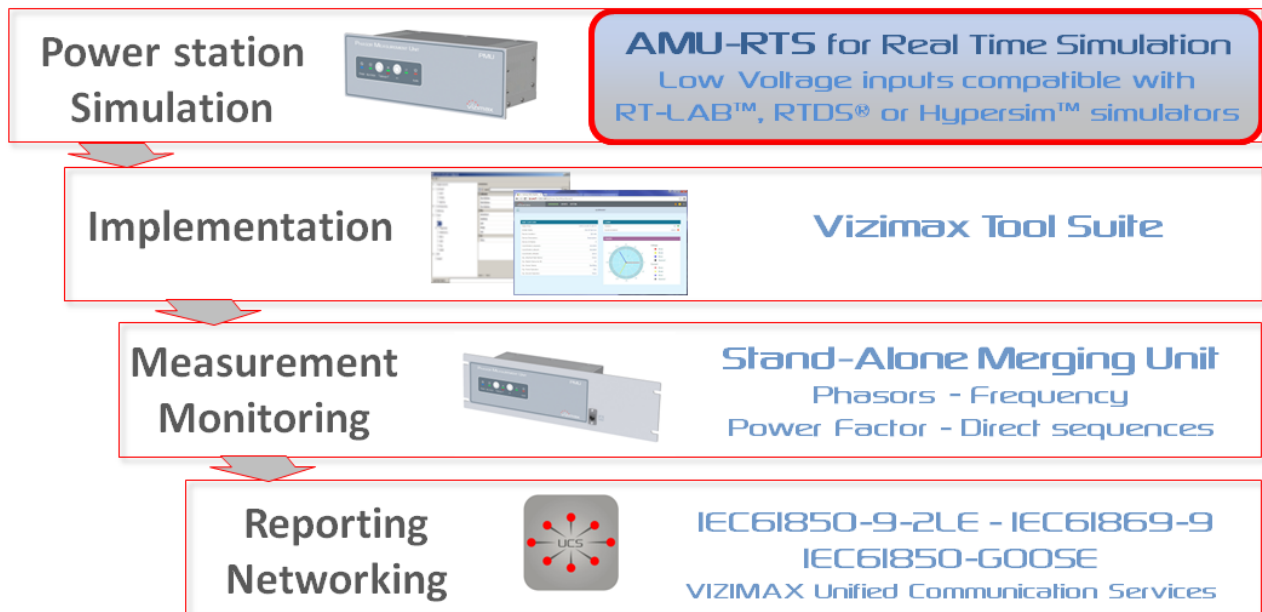

The **AMU-RTS** unit is available with the following hardware configuration:

- Power Supply: 24Vdc
- AC input current measurement: 10Vrms input range.
- AC input voltage measurement: 10Vrms input range.
- Digital inputs: 10 inputs
- High current – high speed digital outputs: 6 floating outputs
- Signalization outputs: 4 electromechanical relay outputs

The mechanical mounting configuration, the time synchronization and the Ethernet communication ports are customer selectable at unit order. Please refer to the Smart coding document (MGU010000-SC) for more details on the available options.

SPECIFICITIES FOR THE AMU-RTS PRODUCT

POWER SUPPLY (FOR AMU-RTS MODEL)

Parameter	Value
Power supply rating (24 V)	12 V dc - 36 V dc (Universal 24V dc power supply adapter (100-240V ac/ 50-60Hz) included with AMU-RTS unit).
Rated power	29 W max. (typical 18 W)
Connector	Phoenix MSTB 5.08 mm
Isolation	3000 V during 1 s
Fuse	Time delay, 2 x 2 A (not user serviceable)
Maximum Voltage interrupt	100 ms @ 100%

NOTE: This table is applicable to AMU-RTS model only.



DIGITAL INPUTS (FOR AMU-RTS MODEL)

The AMU-RTS offers 10 digital inputs split in 2 groups, one of 6 inputs with one common and a group of 4 with their own common.

Parameter	Value
Name	DI1 to DI10
Number of inputs	10 (4 on connector M + 6 on connector N)
Maximum input voltage (24V power supply)	36 V dc, (detection threshold 10 V dc)
Isolation	Opto-coupler, 2000 VRMS
Measuring Category	MEAS CAT IV
Burden	2 mA to 5 mA
Maximum Hardware Response Time	0.10 ms at nominal voltage 1.00 ms at 80% of nominal voltage
Software Filter	Programmable, 1 ms increments up to 250ms. Advanced chatter filter
Connector	Phoenix MSTB 5.08mm, pluggable screw type.

NOTE: This table is applicable to AMU-RTS model only.

HIGH CURRENT DIGITAL OUTPUTS (FOR AMU-RTS MODEL)

The AMU-RTS offers 6 high current digital outputs.

Parameter	Value
Name	Out1 to Out6
Number of outputs	6
Output driver technology	Solid State, independent, sourcing or sinking outputs
Rated voltage	10 V dc -280 V dc
DC rated Output current	5 A dc continuous, 22 A for 1s, 35 A for 200 ms, 70 A pulsed 10 ms
Maximum breaking current	7A @ L/R=40ms
Isolation	2000 VRMS
Switching Frequency	Up to 20Hz (with 100 kΩ load) Up to 250Hz (with current load >1A)
Over Voltage Category	OVC CAT III
Connector	Phoenix MSTB 5.08mm, pluggable screw type

NOTE: This table is applicable to AMU-RTS model only.

ANALOG CURRENT MEASUREMENT INPUTS (FOR AMU-RTS MODEL)

AMU-RTS model: To be compatible with the simulator's output signals, the AC current measurement inputs have been converted and scaled to receive a 10 VRMS signal.

Parameter		Value
Number of inputs		4
Name		IA, IB, IC and IN
Connector type		Phoenix PC-6, 10.16mm, pluggable screw type AWG 7-18 (10.5 mm ² – 0.75 mm ²)
Voltage	Rated voltage	10 V ac (whatever the rated current 1A or 5A selected in the application configuration file)
	Saturation voltage	10.6 V ac
	Maximum voltage	10.6 V ac
Measurement category		Not Isolated
Maximum Burden		0.01 VA @ 10V
Isolation		NA. Negative side connected to P.E
Measurement accuracy with 100% asymmetrical current		Typical: 100% Guaranteed: 100%
Nominal frequency range		40 Hz to 70 Hz
Measurement bandwidth (-3 dB)		DC to 3 kHz
Sampling frequency		19200/s
Conversion resolution		16 bits
CT angle compensation parameter		±1.00 degree
CT magnitude compensation factor		x0.01 to x1000
Hardware Accuracy		Typical: ±0.03% @ 25 °C + (±6PPM/°C) Guaranteed: ±0.1% @ 25 °C + (± 20PPM/ °C) after 15 minutes warm-up and above 1 V ac

NOTE: This table is applicable to AMU-RTS model only.

ANALOG VOLTAGE MEASUREMENT INPUTS (FOR AMU-RTS MODEL)

AMU-RTS model: To be compatible with the simulator's output signals, the AC voltage measurement inputs have been scaled down to 10 VRMS.

Parameter	Value
Number of inputs	4
Name	VA, VB, VC and VN
Connector type	Phoenix MSTB 5.08 mm, pluggable screw type AWG 13-24 (2.5 mm ² – 0.2 mm ²)
Rated voltage	10 V ac (whatever the rated voltage L-N selected in the application configuration file)
Saturation Voltage	10.6 V ac
Thermal capacity	10.6 V ac
Measurement category	MEAS CAT IV (0 – 150 V ac)
Maximum Burden	0.05 VA
Isolation	1500 VRMS
Nominal frequency range	40 Hz to 70 Hz
Measurement bandwidth (-3 dB)	DC to 3 kHz
Sampling frequency	19200/s
Conversion resolution	16 bits
PT angle compensation parameter	±1.00 degree
PT magnitude compensation factor	x0.01 to x1000
Hardware Accuracy	Typical: ±0.05% @ 25°C + (±10 PPM/ °C) Guaranteed: ±0.1% @ 25 °C + (±15 PPM/ °C) after 15 minutes warm-up and above 1 V ac

NOTE: This table is applicable to AMU-RTS model only.

NOTE: All other AMU-RTS specifications are similar to the standard product specifications.

ORDERING INFORMATION

MGU010000: Standalone Merging Unit (AMU)

AMU base unit includes: 4x CT inputs (1A or 5A) + 4x PT inputs + 10x digital inputs + 4x digital signaling outputs (2x Form C + 2x Form A) + 2x serial ports + 3x RJ45 Ethernet 100BASE-T ports (1 reserved for service port) + 2x PPS/IRIG-B inputs (1x fiber optic ST input + 1x BNC input/output): Support IEC 61850-9-2LE, IEC 61869-9, IEC 61850-GOOSE publisher, IEC 61850 MMS Server Ed.2 and Modbus (slave) protocols.

When ordering your AMU, the following configuration options must be defined: mounting configuration, power supply voltage and CT's inputs rating current.

Other additional options are also available:

Option MGC010000: Ethernet ports 1 and 2: Replace 2xRJ45 by 2x Fiber Optic ST multimode

Option MGC020000: Ethernet ports 1 and 2: Replace 2xRJ45 by 2x Fiber Optic LC single mode

Option MGC021000: Ethernet ports 1 and 2: Replace 2xRJ45 by 2x Fiber Optic LC multimode

Option MGC000100: Add built-in GPS receiver

Option MGC001000: Add six (6) high current digital outputs for Circuit breaker control. This option enables the IEC 61850 GOOSE subscriber protocol with XCBR control model.

Please refer to the 'smart coding' document 'MGU010000-SC' for more details about all AMU options or AMU-RTS model.

To download the AMU smart coding document, please use the following link:

<https://www.vizimax.com/publications/>

Vizimax also offers commissioning and training services: for more details, please contact us.

NOTE: These specifications are subject to change without prior notice.



Support contact:

mu.support@Vizimax.com
www.Vizimax.com/support

Vizimax, the Vizimax logo, RightWON, WiseWON, SynchroTeq, SynchroTeq Plus and the RightWON icons are trademarks or registered trademarks of Vizimax, Inc. in Canada, the United States and other jurisdictions. All other trademarks, registered trademarks and service marks are the property of their respective owners.

V-FOPR03-011en (2016-03-22)