



PHASOR MEASUREMENT UNIT (PMU)

DATASHEET



(Panel mount configuration shown here)

PMU010000

2024-04-30

©2024 Vizimax Inc. All rights reserved

TABLE OF CONTENT

TABLE OF CONTENT	2
PRODUCT OVERVIEW	4
VIZIMAX PMU - MAJOR FEATURES	5
HARDWARE HIGHLIGHTS	5
OPERATING ENVIRONMENT	6
TIME SYNCHRONIZATION	7
TIME SYNCHRONIZATION SERVER MODE	7
COMMUNICATION LINKS.....	8
DATA: ACQUISITION AND REPORTING.....	9
<i>RMS Values: Calculation and Publishing</i>	10
OPTIONAL 61850 GOOSE CIRCUIT BREAKER CONTROL MODEL (XCBR).....	12
TYPICAL TARGETED APPLICATIONS	13
TECHNICAL SPECIFICATIONS	14
<i>Compliance and Certifications</i>	14
<i>Type Tests</i>	14
<i>Temperature Test Performances</i>	15
POWER SUPPLY	16
CONTROL AND COMMUNICATION	17
<i>Controller</i>	17
<i>Internal Time Base and Time Synchronization</i>	17
<i>Local User Interface</i>	18
<i>Communication ports</i>	18
MEASUREMENT AND COMPUTING	19
<i>Analog current measurement inputs (CT for standard PMU models)</i>	19
<i>Analog voltage measurement inputs (PT for standard PMU models)</i>	20
<i>Synchrophasors</i>	21
DIGITAL INPUTS / OUTPUTS.....	22
<i>Digital inputs (optional)</i>	22
<i>Circuit breaker control Outputs (optional)</i>	23
<i>Signalization digital outputs</i>	23
DATA REPORTING AND CONTROLS	24
<i>Phasors reporting (C37.118)</i>	24
<i>Optional Sampled Value Reporting (IEC 61850-9-2LE / IEC 61869-9)</i>	25
<i>61850-GOOSE publisher reporting</i>	25
<i>IEC 61850-GOOSE Subscriber with XCBR Control model</i>	26
<i>IEC 61850 MMS Server Ed.2</i>	27

<i>MODBUS protocol (Slave)</i>	27
MOUNTING CONFIGURATIONS	28
<i>Standard Mount (standalone)</i>	28
<i>Panel Mount</i>	30
<i>Rack Mount</i>	31
ABOUT THE PMU-RTS (REAL TIME SIMULATION) MODEL	32
SPECIFICITIES FOR THE PMU-RTS PRODUCT	33
<i>Power supply (for PMU-RTS model)</i>	33
<i>Digital inputs (for PMU-RTS model)</i>	34
<i>High current Digital Outputs (for PMU-RTS model)</i>	34
<i>Analog current measurement inputs (for PMU-RTS model)</i>	35
<i>Analog voltage measurement inputs (for PMU-RTS model)</i>	36
ORDERING INFORMATIONS	37

PRODUCT OVERVIEW

The Vizimax Phasor Measurement Unit (PMU) is a high accuracy platform for acquisition and fast data publishing (current and voltage synchrophasors, current and voltage direct sequences, frequency and ROCOF) for advanced high and medium voltage power system monitoring, protection and control.

As a key element of the Wide Area Measurement Systems (WAMS), Vizimax's PMU exceeds C37.118 requirements for both M and P class accuracy, offering an adjustable publishing rate up to 200/240 frames per second (50/60Hz) and a highly accurate and very fast ROCOF calculation.

P class accuracy equals M class accuracy for a publishing rate of up to 60 frames per second.

Vizimax's PMU offers real-time access to remote time synchronized analog data providing situational awareness. It improves the reliability on the control actions reducing uncertainty in the decision-making.

The Vizimax PMU's time synchronization can be achieved via external equipment (i.e IRIG-B/PPS), or via network link (i.e PTP1588, NTP). An optional built-in GPS Receiver allows for the PMU's time synchronization even though no other external synchronization source is available. When synchronized through PTP1588 or when equipped with its GPS Receiver the Vizimax's PMU can be a precision time synchronization server to adjacent equipment.

Its robust platform combined with innovative adaptive filtering technics and exceptional resilience to harmonics provides an ideal approach in stressed and disturbed power systems, microgrids, electrical islands as well as renewable energy and storage systems. It can be bundled with the Vizimax RightWON controller for the implementation of customized control schemes and advanced protection applications.

The IEC 61850-GOOSE subscriber protocol with the XCBR model is supported with the PMC001000 option (+10 digital inputs, + 6 high current - high speed outputs) to control a 3-phase circuit breaker.

Vizimax's PMU supports a series of C37.118 commands allowing to control the optional PMU digital outputs. It also supports the Modbus TCP/RTU (slave) protocol thus allowing industrial equipment and controllers to leverage its data streams.

Vizimax's PMU also offers the option to publish analog values in the form of sampled values (SV) that comply with the light edition (LE) of the IEC 61850-9-2 and with the IEC 61869-9 standard. The unit provides the capability of sampling and transmitting data according to the Protection portion of the standard or based on the Measurement portion of the standard and can publish two IEC data streams simultaneously, no matter the format.

Vizimax also offers a **PMU-RTS version** (Phasor Measurement Unit for Real-Time Simulation) suitable for hardware-in-the-loop **Real-Time Simulation** environment such as OPAL-RT's RT-LAB or Hypersim, or RTDS Technologies' RTDS.

VIZIMAX PMU - MAJOR FEATURES

- Current and voltage phasors, frequency and ROCOF measurements exceeding C37.118 requirements for both M and P classes.
Adjustable reporting rates: Up to 200/240 frames per second for 50/60 Hz
- Highly resilient and reliable at rejecting harmonics and out of band interferences, making it the ideal approach for microgrids, power islands or renewable energy systems.
- Broad variety of time synchronization methods from external sources and precision clocks, either standalone or networked.
- Optional built-in GPS Receiver allowing for precision time synchronization even in the absence of external sources or clocks.
- Precision time synchronization server: synchronize other devices, IEDs, controllers when fitted with the built-in GPS Receiver or when synchronized via PTP 1588.
- IEC 61850 GOOSE Messaging Publisher.
- IEC 61850 MMS Server Ed.2 (with firmware 1.5 and up).
- IEC 61850 GOOSE Messaging Subscriber (with PMC001000 option).
- C37.118 commands and Modbus TCP/RTU connectivity (slave) allowing for data sharing with industrial equipment.
- RMS calculated values dataset for C37.118 publishing or Modbus data transfer.
- Optional sampled values reporting with IEC 61850-9-2LE and IEC 61869-9 standard.

HARDWARE HIGHLIGHTS

- Very fast and accurate ROCOF availability (1.2 to 3.25 cycles max)
- Total Vector Error (TVE) under 0.20% in steady conditions
- Unique adaptive algorithms that work under a wide frequency range, especially in dynamic conditions (can work within a range of ± 18 Hz around a selected base frequency).
- High precision, 20-bit accuracy on current inputs and 16-bit accuracy on voltage inputs.
- CT inputs support extended dynamic range (DR) up to 160 A (for 5A range).
- 4 dry contacts relay outputs for alarm signalization.
- Optional 10x digital inputs + 6x high current digital outputs to control circuit breaker (PMC001000 option).
- Accommodates a wide temperature range: from -40 °C up to +85 °C.
- Local HMI and secured web-based configuration and operation interface.

OPERATING ENVIRONMENT

The Vizimax PMU combines the acquisition of AC currents and voltages from conventional transformers (CT and PT) and converts these signals into digital time-synchronized phasor values called ‘Synchrophasors’.

The phasors data and frequency related measurements are published per the IEEE C37.118 protocol. The data frame is sent at the specified rate to other systems, be it protection systems, phasor data concentrators (PDC) or WAMS and EMS monitoring systems. Real-time automation solutions can be designed using the Vizimax RightWON automation platform companion product that supports the C37.118 client.

Thanks to its platform, the Vizimax PMU can be installed in a substation control room or integrated in outdoor equipment junction box.

In its operating environment, the PMU device is connected to several components or systems as shown in Figure 1.

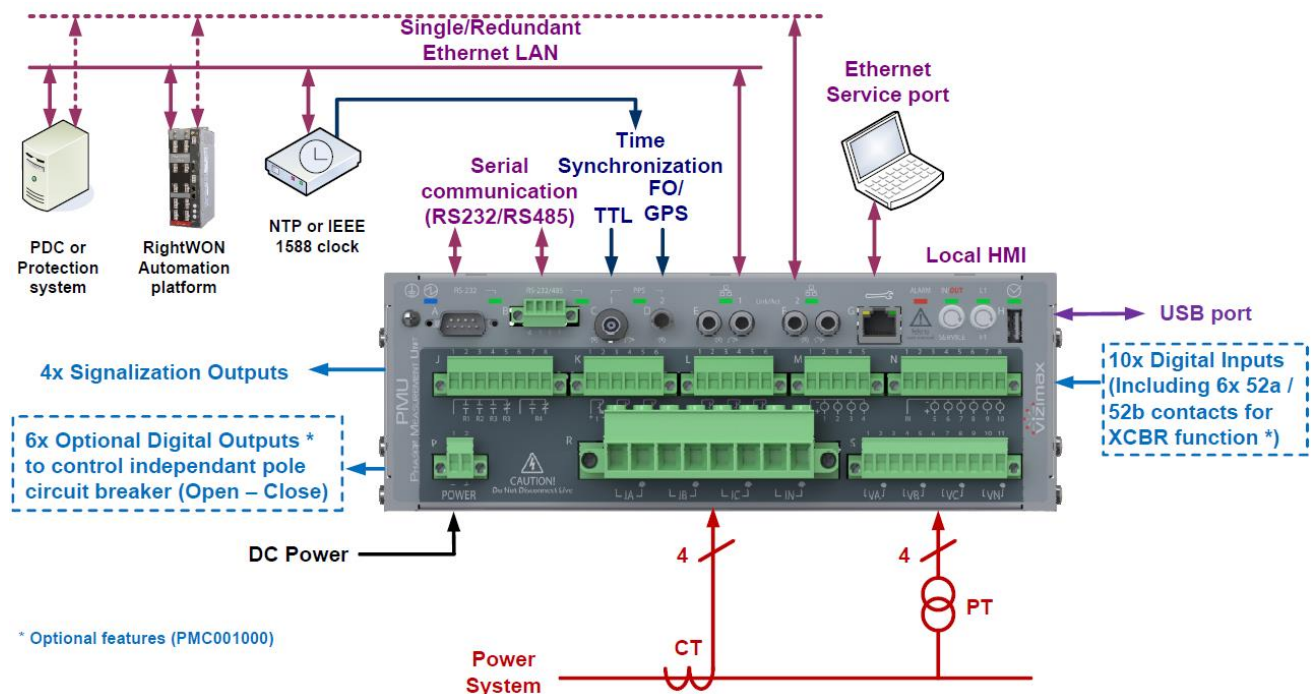

FIGURE 1 PMU IN ITS OPERATING ENVIRONMENT

The VIZIMAX PMU has a capability of publishing the signalization output states and the digital IOs states using IEC 61850-GOOSE publisher protocol. This functionality allows fast data exchange with protection systems and automation platforms.

The PMC001000 option allows controlling a 3-phase circuit breaker (independent poles) with the 6 power outputs by subscribing to GOOSE messaging.

TIME SYNCHRONIZATION

Vizimax PMU's time synchronization can be achieved by either:

- **An external device:**
 - IRIG-B un-modulated signal:
 - IRIG-B000/B004 C37.118
 - IRIG-B000/B004 IEEE1344
 - IRIG-B signal received through either:
 - fiber optic – ST connector
 - copper – BNC-TTL
- **A network link:**
 - IEC 61588 (IEEE 1588) PTP compliant master clock: Ethernet port 1 and 2 include specific hardware for a full PTP1588 compatibility (multiple profiles incl. IEC 61850-9-3).
 - SNTP Client – Server service enhanced with BNC-TTL or IR fiber PPS inputs
- **In Stand-alone:**
 - By using the optional built-in GPS receiver (Option PMC000100).

Any one of these approaches renders the required accuracy to transmit synchrophasor data in conformance with the IEEE C37.118 standard.

TIME SYNCHRONIZATION SERVER MODE

Vizimax PMU has the capability of providing time synchronization source to other equipment:

- PTP1588 time synchronization server (master clock with leap second support): requires the optional built-in GPS receiver or a connection to another PTP1588 time synchronization source.
- NTP time synchronization server (UTC format support): requires the optional built-in GPS receiver or a connection to another time synchronization source providing UTC time data.
- High accuracy PPS output signal available to other devices via the BNC connector (when not used as an input).

COMMUNICATION LINKS

The PMU provides 3 Ethernet ports:

- Port 1 and 2 can be configured for C37.118 communications, optional 61850-9-2 / 61869-9 communications, GOOSE messaging as well as for time synchronization and secured access to web interface and configuration tools:
 - Standard: Copper Ethernet connections (100BASE-T) with RJ-45 connectors
 - Option PMC010000: Replace 2xRJ45 by 2x Fiber-optic connections 100BASE-FX with ST connectors multimode (allowing 2km transmission)
 - Option PMC020000: Replace 2xRJ45 by 2x Fiber-optic connections 100BASE-LX with LC connectors Single mode (allowing 10km transmission)
 - Option PMC021000: Replace 2xRJ45 by 2x Fiber-optic connections 100BASE-FX with LC connectors multimode (allowing 2km transmission)
- Port 3 located on the PMU's back panel (or front panel in the 19" rack configuration) is used as a local service port or for remote maintenance (RJ-45 connector).

The PMU provides 2 serial links:

- The RS232 port A.
- The RS485-RS232 configurable port B.

The PMU offers a user-friendly graphical web operating interface. Furthermore, the Vizimax Tool Suite for Microsoft Windows provides a rich environment for the remote configuration of the unit and data analysis.

DATA: ACQUISITION AND REPORTING

The Vizimax PMU combines the acquisition of analog and digital data and reports this information under various format and protocols after processing in the PMU algorithm. The secured Web interface also displays an extensive set of information as shown in Figure 2.

Data published through C37.118 and 61850-GOOSE formats are time stamped with accuracy better than 1ms and can be used for real time applications as well as for offline analysis.

Analog values and digital signal states can be reported over the Modbus protocol. This protocol also allows controlling (force) the optional high current digital outputs, as well as some specific C37.118 commands.

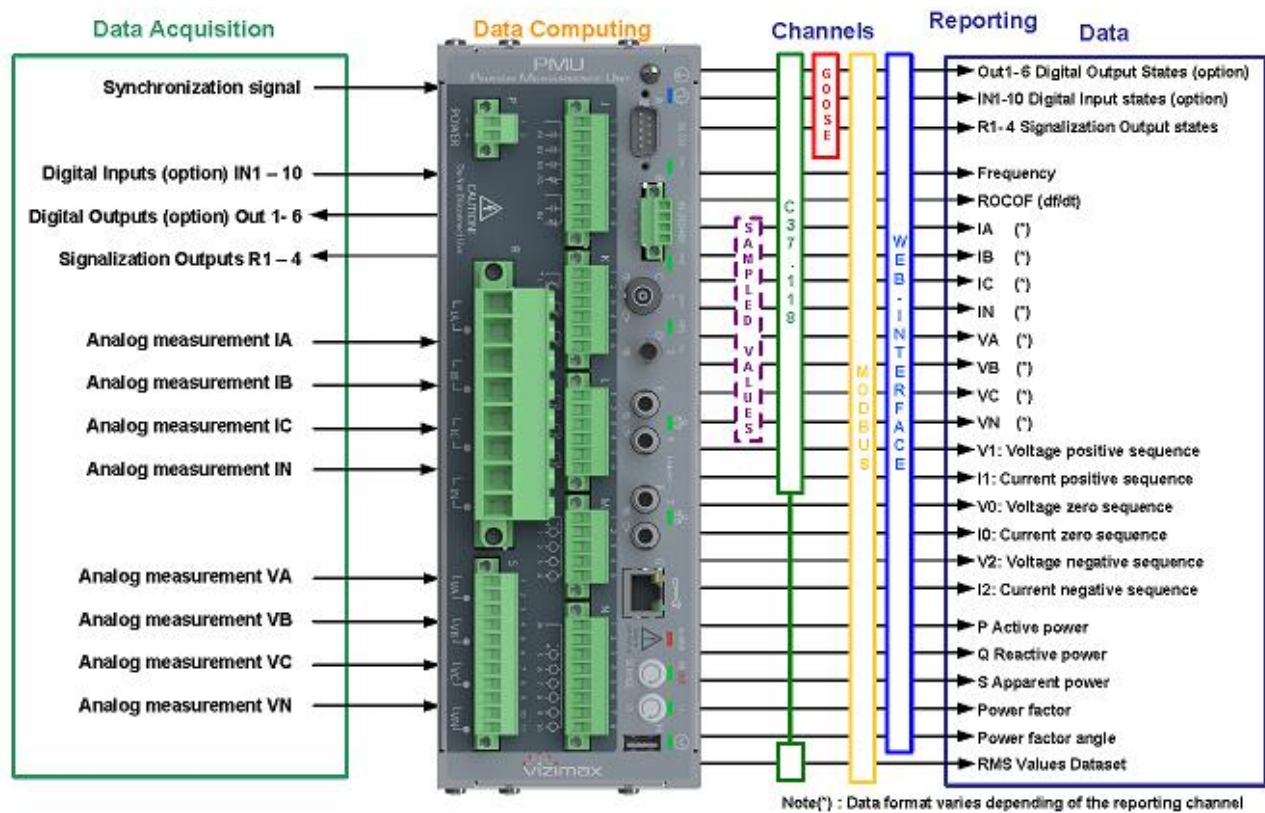

FIGURE 2 DATA ACQUISITION AND REPORTING - DISPLAY

PMU device ordered with the ‘Sampled Values’ reporting option (option PMC000200) can also publish analog values in the form of sampled values (SV) that comply with the light edition (LE) of the IEC 61850-9-2 and the IEC 61869-9 standard.

Note 1: Starting firmware 1.4 and up, Vizimax unit delivered with the PMC001000 option (adding 10 digital inputs and 6 high current - high speed outputs) support the GOOSE subscriber protocol with the XCBR model allowing controlling a 3-phase circuit breaker (independent poles).

Note 2: Starting firmware 1.5 and up, PMU unit supports the MMS server Ed.2 protocol.

RMS VALUES: CALCULATION AND PUBLISHING

Starting from firmware version 1.3, Vizimax PMU provides customers with a new feature for RMS values calculation and publishing over the C37.118 protocol (Analog Values) and Modbus.

The calculated RMS values are:

- RMS Voltage (Vrms) for phase A/B/C and Neutral
- RMS Current (Irms) for phase A/B/C and Neutral
- RMS Apparent Power (Srms) for phase A/B/C and Neutral
- RMS Active Power or Real Power (Prms) for phase A/B/C and Neutral
- RMS Non-Active Power (Nrms) for phase A/B/C and Neutral

RMS Calculations

RMS calculations are made on raw data, at a rate of 14400 acquisitions per seconds (69.44uS per sample), giving 240 samples per cycle at 60Hz and 288 samples per cycle at 50Hz.

The length of the buffer (N) in the formulae below depends on the 'RMS integration time parameter'. This parameter can be set to 100ms, 200ms, 500ms or 1s. For example, if 'RMS Integration Time' is set to 200ms, as the sample time = 69.44uS, then N = 2880

RMS Voltage:

$$V_{rms} = \sqrt{\frac{1}{N} \sum_{i=1}^N x_i^2} \quad \text{where } X_i \text{ are the samples of voltage for phase A/B/C and neutral}$$

RMS Current:

$$I_{rms} = \sqrt{\frac{1}{N} \sum_{i=1}^N x_i^2} \quad \text{where } X_i \text{ are the samples of current for phase A/B/C and neutral}$$

RMS Apparent Power:

$$S_{rms} = \frac{1}{N} \sqrt{\sum_{i=1}^N U_i^2 \sum_{i=1}^N I_i^2} \quad \text{where } U_i \text{ and } I_i \text{ are the simultaneous samples of respectively the voltage and current for phase A/B/C and neutral}$$

RMS Active Power (or Real Power):

$$P_{rms} = \frac{1}{N} \sum_{i=1}^N u_i i_i$$

RMS Non-Active Power:

$$N_{rms} = +/- \sqrt{S^2 - P^2}$$

NOTE: The sign of "N" is taken from the sign of the synchrophasor (fundamental frequency calculation) of reactive power Q, updated 240 times per second, at the end of RMS integration time.

RMS values Publishing in C37.118

Calculated RMS values are published as Analog Values (Floating Point format only) in the C37.118 data stream.

RMS values Publishing in Modbus

Calculated RMS values are also available in the Modbus 'Analog Input Registers'.

Those values are updated at each 'RMS Integration Time' period.

OPTIONAL 61850 GOOSE CIRCUIT BREAKER CONTROL MODEL (XCBR)

Starting firmware 1.4 and up, Vizimax unit delivered with the PMC001000 option (adding 10 digital inputs and 6 high current - high speed outputs) support the GOOSE subscriber protocol with the XCBR model allowing controlling a 3-phase circuit breaker (independent poles).

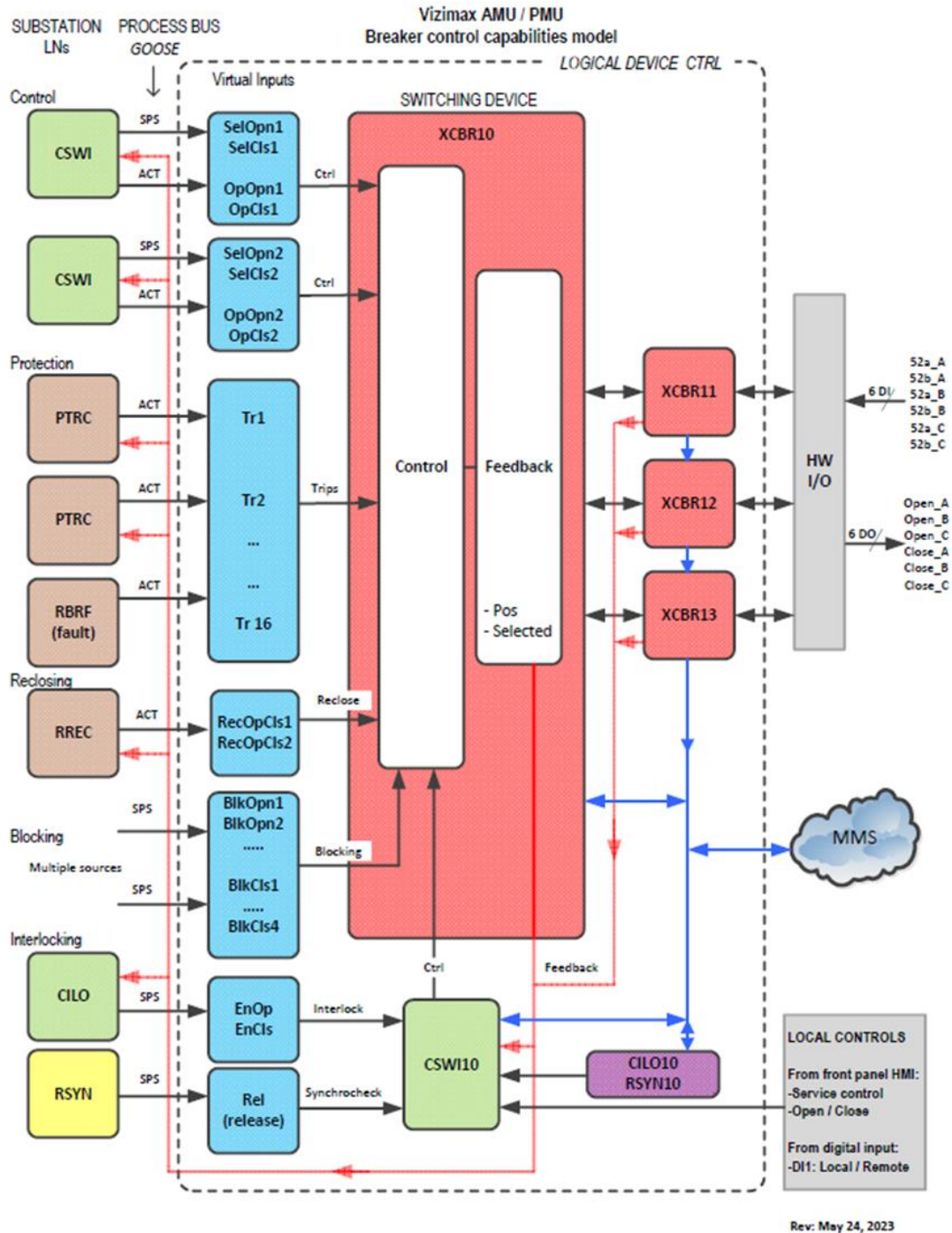

FIGURE 3 PMU 61850 GOOSE SUBSCRIBER XCBR CAPABILITIES MODEL

TYPICAL TARGETED APPLICATIONS

With its outstanding performances in measuring, computing and reporting synchronised data, Vizimax Synchrophasor responds to existing monitoring and control systems. It also opens the doors to a new era in real time WAMS and EMS applications, to deliver reliable and high quality energy.

Real time application examples

- Increase a transmission system operator’s situational awareness on the state of the extended grid (his and his neighbours’) in real time through drastically improved state estimation.
- Increase a transmission or distribution system operator’s situational awareness on the state of the grid in real time (microgrids, islanded networks, etc.).
- Real time ROCOF monitoring by a power producer allowing instantaneous active power adjustment using local spinning or reserve resources.
- Real time voltage monitoring by a power producer (wind farm, solar plant etc.) subject to a TSO/DSO’s voltage regulation constraints at the point of delivery, allowing instantaneous reactive power adjustment by using local compensation resources (capacitor banks, shunt reactors, WTG rectifiers, etc.).

Offline application examples

- Use a fleet of PMUs within a Wide Area Measuring/Monitoring System (WAMS) for the post-mortem analysis of incidents (e.g., a black out). Since all PMUs report measurements that share the exact same time tag, the WAMS can combine them all to provide an accurate status of the condition of the grid, one millisecond at a time. The WAMS does not need to rely on the very approximate modeling of the network (real-time topology, line impedances....) that traditional EMS systems are limited by.

Typical PMU setup

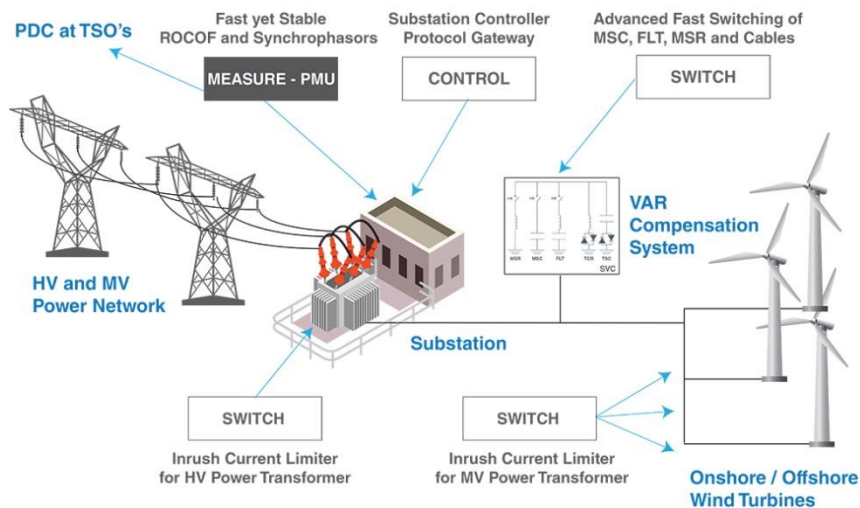

TECHNICAL SPECIFICATIONS

COMPLIANCE AND CERTIFICATIONS



NOTE:The IEEE Certification Mark, the design mark, and the term "IEEE Certified" are certification marks of IEEE, and cannot be used without the written authorization of IEEE.

This device has been certified by ICAP as of March 21, 2016.

TYPE TESTS

Type Tests		Standard	Value
Temperature range	Operating temperature		-40 °C to +85 °C (*see note)
	Storage temperature		-50 °C to +85 °C
Maximum Relative humidity (R.H.)		IEC 60068-2-30	95% without condensation
Maximum altitude		IEC 61010-1	2000 m
IP rating		IEC 60529	IP30
Normal environmental conditions		IEC 60255-1 IEC 60947-1	- No significant air pollution - Pollution degree 2
Mechanical resistance to vibrations	Performance	IEC 60255-21-1, 21-2, 21-3	Class 2
	Endurance	IEC 60255-21-1, 21-2, 21-3	Class 1
Dielectric withstand	AC inputs and I/Os	IEC 60255-5	2200 V ac, 1 s
	Communication	IEC 60255-5	1650 V ac, 1 s
Impulse voltage withstand		IEC 60255-5	5 kV
Electrostatic discharge (ESD)	Air discharge	IEC 61000-4-2	15 kV
	Direct contact discharge	IEC 61000-4-2	8 kV
Surge Immunity test		IEC 61000-4-5	Level 4
Damped oscillatory wave (1 MHz burst)	Common mode	IEC 60255-22-1	2.5 kV
	Differential mode	IEC 60255-22-1	1.0 kV

Type Tests	Standard	Value
Fast transients (bursts)	IEC 60255-22-4	Level 4
RF immunity	IEC 61000-4-3	20 V/m, from 80 MHz to 1 GHz
	IEC 60255-26	Spot frequency: 80 MHz to 2150 MHz
	ANSI/IEEE 1613	10 V/m, from 1.4 GHz to 2.7 GHz
	SN62. 1008-1	3 V/m, from 5.15 GHz to 5.75 GHz
Conducted disturbance immunity	IEC 61000-4-6	150 kHz to 80 MHz
RF emissions	CISPR 11, CISPR 22, FCC	Class A
Safety	IEC 61010-1, 3 rd edition ISO 14971: 2012	Equipment for measurement, control, and laboratory use

*Internal operating temperature; please refer to 'Temperature Test Performances' table below for more details.

TEMPERATURE TEST PERFORMANCES

Type Tests	Standard	Value
Temperature Type testing	Cold	IEC 60068-2-1 -40 °C (16 hours) after cold start at -50 °C
	Dry heat	IEC 60068-2-2 +70 °C (16 hours)
	Damp heat cyclic	IEC 60068-2-30 +55 °C at 95% R.H. (144 hours)
	UL Safety	IEC 61010-1 -40 °C to +70 °C

POWER SUPPLY

Power supply for standard PMU model

The power supply is set in factory according to the ordering option.

Parameter	Value
Power supply rating (48 V)	36 V dc - 72 V dc
Power supply rating (125 V)	90 V dc - 140 V dc
Power supply rating (220 V)	180 V dc - 280 V dc
Rated power	29 W max. (typical 18 W, 0.14 A @ 125 V dc)
Connector	Phoenix MSTB 5.08 mm
Isolation	3000 V during 1 s
Fuse	Time delay, 2 x 2 A (not user serviceable)
Maximum Voltage interrupt	100 ms @ 100%

NOTE: This table is applicable to PMU standard model only.

CONTROL AND COMMUNICATION

CONTROLLER

Parameter	Value
Main processor	32-bit, 800 MHz multi cores A9 high performance ARM processor
OS	Linux
Memory	512 MB Flash memory /512 MB RAM
Real time clock	Autonomy is 36 hours without power (no battery required)
I/O board controller	32 bits, 168 MHz ARM processor with RTOS. 16 bit ADC.

INTERNAL TIME BASE AND TIME SYNCHRONIZATION

Parameter	Value
Base precision	Better than 100 nanosecond, after 15 minutes warm-up
Time for a drift of 1.0 μ s on external time base lost	Typical: \approx 1200 s Guaranteed: 400 s @ 25 °C no movement, after 15 minutes warm-up
Ethernet – SNTP (client & Server)	RJ45, Fiber ST or Fiber LC Base precision \leq 1 millisecond
Ethernet - IEEE PTP 1588	RJ45, Fiber ST or Fiber LC Base precision \leq 25 nanoseconds
IRIG-B un-modulated or PPS-in over fiber optic	ST type frequency range: 820-850 nanometers Base precision \leq 75 nanoseconds
IRIG-B un-modulated or PPS-in over BNC	Zin: 500 Ω /50 Ω selectable by software Level: 3.3 V dc to 5.0 V dc Base precision \leq 85 nanoseconds
PPS-out over BNC	Zout: 10 Ω Vout: 5.0 V dc, Iout max = 100 mA
Built-in GPS receiver option (*)	GPS option replaces PPS fiber optic input with a SMA antenna connector. Base precision \leq 45 nanoseconds

NOTE: (*) GPS antenna and accessories are not included in the Built-in GPS receiver option.

LOCAL USER INTERFACE

Parameter	Value	
Two push buttons (back side and front side)	<ul style="list-style-type: none"> - In/Out of service - C/B Open / Close (when XCBR control is activated) 	
Ten LED (back side)	Service, alarm (2x), communication activity (3x), time synchronization, system status, C/B position and power	
Five LED (front side)	Service, alarm, system status, C/B position and power	
USB port	Interface compatibility	2.0
	Maximum speed	480 Mbit/s
	Connector type	Type A
	Voltage isolation level	N/A

COMMUNICATION PORTS

Port	Characteristic	Value
Ethernet – LAN-1	Interface	10/100 Mbps
	Connector	RJ-45, ST or LC (for fiber connection)
	Isolation	1500 VRMS
	Connector name	Port 1
	Function	User communication link
Ethernet – LAN-2	Interface	10/100 Mbps
	Connector	RJ-45, ST or LC (for fiber connection)
	Isolation	1500 VRMS
	Connector name	Port 2
	Function	User communication link
Ethernet – Service (back)	Interface	10/100 Mbps
	Connector	RJ-45
	Isolation	1500 VRMS
	Connector name	Port service–initial unit configuration and setup
	Function	Service port
RS-232 serial	Connector	DB-9
	Bit rate	115 Kbps
	Function	Console port, service operations
RS232 or RS-485 isolated serial	Connector	Phoenix type, 3.81 mm secured by screws
	Bit rate	38.4 Kbps
	Mode	Two wire interface (A-B) with jumper selectable 120 Ω terminations. Reference wire (0V) provided for high-common-mode voltage capability
	Isolation	2000 VRMS
	Function	(Reserved for internal use)

MEASUREMENT AND COMPUTING

ANALOG CURRENT MEASUREMENT INPUTS (CT FOR STANDARD PMU MODELS)

Parameter	Value	
Number of inputs	4	
Name	IA, IB, IC and IN	
Connector type	Phoenix PC-6, 10.16mm, pluggable screw type AWG 7-18 (10.5 mm ² – 0.75 mm ²)	
Current	Rated current	1 A or 5 A, manufacturing selectable
	Saturation current	160 A @ 5 A range / 40 A @ 1 A range
	Maximum current	500 A @ 1.0 s, 160 A @ 10.0 s, 42 A @ 100.0 s 20 A continuous
Measurement category	MEAS CAT IV	
Maximum Burden @ rated current	0.01 VA @ 1 A 0.1 VA @ 5 A 4 VA @ 42 A	
Isolation	3000 VRMS	
Measurement accuracy with 100% asymmetrical current	Typical: 98% Guaranteed: 95%	
Nominal frequency range	40 Hz to 70 Hz	
Measurement bandwidth (-3 dB)	DC to 3 kHz	
Sampling frequency	19200/s	
Conversion resolution	20 bits	
CT angle compensation parameter	±1.00 degree	
CT magnitude compensation factor	x0.01 to x1000	
Hardware Accuracy 5 A or 1A range	Typical: ±0.03% @ 25 °C + (±6PPM/°C) ≤14 A (5A) or ≤3.5 A (1A) Guaranteed: ±0.1% @ 25 °C + (± 20PPM/ °C) ≤14 A (5A) or ≤3.5 A (1A) ±0.5 to 0.8% @ 25 °C + (± 125PPM/ °C) >14 A (5A) or >3.5 A (1A) after 15 minutes warm-up	
Synchrophasor Accuracy Magnitude**	Typical: ±0.06% @ 25 °C + (±6PPM/°C) ≤14 A (5A) or ≤3.5 A (1A) Guaranteed: ±1.0% @ 25 °C + (± 20PPM/ °C) ≤14 A (5A) or ≤3.5 A (1A) ±1.2% @ 25 °C + (± 125PPM/ °C) >14 A (5A) or >3.5 A (1A) after 15 minutes warm-up	
Synchrophasor Accuracy Angle**	Typical: ±0.05 degree @ 25 °C + (±6PPM/°C) ≤14 A (5A) or ≤3.5 A (1A) Guaranteed: ±0.5 degree @ 25 °C + (± 20PPM/ °C) ≤14 A (5A) or ≤3.5 A (1A) ±0.8 degree @ 25 °C + (± 125PPM/ °C) >14 A (5A) or >3.5 A (1A) after 15 minutes warm-up	

NOTE: This table is applicable to standard PMU model only

NOTE: (**) Estimated value confirmed by all test sequences performed during C37.118 certification.

ANALOG VOLTAGE MEASUREMENT INPUTS (PT FOR STANDARD PMU MODELS)

Parameter	Value
Number of inputs	4
Name	VA, VB, VC and VN
Connector type	Phoenix MSTB 5.08 mm, pluggable screw type AWG 13-24 (2.5 mm ² – 0.2 mm ²)
Rated voltage	57.7 V ac to 138.6 V ac (L-N)
Saturation Voltage	220 V ac
Thermal capacity	220 V ac @ continuous
Measurement category	MEAS CAT IV (0 – 150 V ac) MEAS CAT III (150 – 300 V ac)
Maximum Burden	0.05 VA
Isolation	3000 VRMS
Nominal frequency range	40 Hz to 70 Hz
Measurement bandwidth (-3 dB)	DC to 3 kHz
Sampling frequency	19200/s
Conversion resolution	16 bits
PT angle compensation parameter	±1.00 degree
PT magnitude compensation factor	x0.01 to x1000
Hardware Accuracy	Typical: ±0.05% @ 25°C + (±10 PPM/ °C) Guaranteed: ±0.1% @ 25 °C + (±15 PPM/ °C) after 15 minutes warm-up and above 20 V ac
Synchrophasor Accuracy Magnitude**	Typical: ±0.06% @ 25°C + (±10 PPM/ °C) Guaranteed: ±1.0% @ 25 °C + (±15 PPM/ °C) after 15 minutes warm-up and above 20 V ac
Synchrophasor Accuracy Angle**	Typical: ±0.05 degree @ 25°C + (±10 PPM/ °C) Guaranteed: ±0.5 degree @ 25 °C + (±15 PPM/ °C) after 15 minutes warm-up and above 20 V ac

NOTE: This table is applicable to standard PMU model only

NOTE: ()** Estimated value confirmed by all test sequences performed during C37.118 certification.

SYNCHROPHASORS

Parameter	Value
Conformance	IEEE C37.118.2-2011 as amended by IEEE C37.118.1a-2014 IEEE 'Synchrophasor Measurement Test Suite Specification' Version2-2015
Accuracy	Class M and P as specified by IEEE C37.118
Measurements	Software selectable
Voltage	VA, VB, VC (3-wire WYE configuration) and VN
Current	IA, IB, IC and IN
Positive Sequence	V1, I1
Periodic	Frequency, ROCOF
Phase Rotation	ABC
Nominal frequency	50Hz – 60Hz
Frequency range	32 Hz - 68 Hz (@50Hz) 42 Hz - 78 Hz (@60Hz)
Measurement Accuracy	Typical: +/- 0.001 Hz above 20 V ac Guaranteed: always better than C37.118 requirement (+/- 0.005 Hz, +/- 0.010 Hz or +/- 0.025 Hz) depending on C37.118 test.

DIGITAL INPUTS / OUTPUTS

DIGITAL INPUTS (OPTIONAL)

The PMU offers 10 optional digital inputs split in 2 groups, one of 6 inputs with one common and a group of 4 with their own common (This option is included in the PMU-RTS model).

When the optional 61850 circuit breaker control (XCBR) is enabled, the group of 6 DI (connector N) is used to report the C/B position contacts (52a and 52b) for each 3 phases.

Parameter	Value
Name	DI1 to DI10
Number of inputs	10 (4 on connector M + 6 on connector N)
Maximum input voltage (48V power supply)	72 V dc, (detection threshold 28 V dc)
Maximum input voltage (125V power supply)	140 V dc, (detection threshold 80 V dc)
Maximum input voltage (220V power supply)	280 V dc, (detection threshold 150 V dc)
Isolation	Opto-coupler, 2000 VRMS
Measuring Category	MEAS CAT IV
Burden	2 mA to 5 mA
Maximum Hardware response Time	0.10 ms at nominal voltage 1.00 ms at 80% of nominal voltage
Software Filter	Programmable, 1 ms increments up to 250ms. Advanced chatter filter
Connector	Phoenix MSTB 5.08mm, pluggable screw type.

NOTE: This table is applicable to PMU standard model only.

CIRCUIT BREAKER CONTROL OUTPUTS (OPTIONAL)

The PMU option PMC001000 offers 6 optional high speed - high current digital outputs including the 61850 GOOSE subscriber protocol. (This option is included in the PMU-RTS model).

Parameter	Value
Name	Out1 to Out6
Number of outputs	6 (3 on connector K + 3 on connector L)
Output driver technology	Solid State, independent, sourcing or sinking outputs
Rated voltage	10 V dc -280 V dc
DC rated Output current	5 A dc continuous, 22 A for 1s, 35 A for 200 ms, 70 A pulsed 10 ms
Maximum breaking current	7A @ L/R=40ms
Isolation	2000 VRMS
Switching Frequency	Up to 20Hz (with 100 kΩ load) Up to 250Hz (with current load >1A)
Maximum time from GOOSE trip message	1 ms
Over Voltage Category	OVC CAT III
Connector	Phoenix MSTB 5.08mm, pluggable screw type

SIGNALIZATION DIGITAL OUTPUTS

The PMU has 4 signaling dry contact (relay) outputs. These outputs allow the unit to send alarm conditions to other IEDs such as RTUs and annunciators.

Parameter	Value
Number of outputs	R1 to R4 2x form A and 2x form C dry contact outputs (1 form C reserved for system health status)
Function	System health, synchronization, In/Out of service, alarm.
Type	Electromechanical relays
Maximum steady AC current	3.0 A at 250 V ac
Maximum steady DC current	2.0 A at 250 V dc
Contact ratings	250 V ac, 300 V dc
Contact breaking capacity	10 A at 250 V ac 8 A @ 30 V, 0.5 A @ 125 V, 0.3 A at 250 V dc
Isolation	5000 VRMS (coil to contacts)
Over voltage category	OVC CAT III
Connector	Phoenix MSTB 5.08 mm, pluggable screw type

DATA REPORTING AND CONTROLS

PHASORS REPORTING (C37.118)

Parameter	Value
Data published in C37.118 stream (if available and enabled)	Voltage Phasors: VA, VB, VC, VN and V1 (positive sequence) Current phasors: IA, IB, IC, IN and I1 (positive sequence) RMS calculated values Dataset (Analog Values) Frequency ROCOF Digital inputs (DI1 to DI10) High current digital outputs (Out1 to Out6) Digital relay outputs (R1 to R4) (Sample Timestamp and Time quality implicitly included in all C37.118 data frame.)

Parameter	Value
Reporting Configuration	2 totally independent C37.118 reporting engines. M or P class (Metering or Protection)
2x clients IP transport	TCP/UDP or UDP spontaneous
Message format	C37.118 (2005, 2011)
Nominal frequency	60 Hz or 50 Hz
Phasor data set	Reporting of each phasor individually enabled.
Messages per second	1, 2, 5, 10, 25, 50, 100, 200 ¹ for 50Hz signal 1, 2, 4, 5, 10, 12, 15, 20, 30, 60, 120, 240 ¹ for 60Hz signal ¹ Higher rates are dedicated to real-time application for customers who wish to deploy fast custom-designed controllers and protection systems for demanding applications.
Other reporting rate	1 per 2s, 1 per 5s, 1 per 10s, 1 per 15s, 1 per 30s, 1 per min
Phasor and numerical format	Integer or float
Analog Values format (RMS)	Floating point only
Phasor format	Rectangular or polar
Frequency and ROCOF format	Integer or float

NOTE: Additional measured and computed data such as active, reactive and apparent power or symmetrical components (zero, positive and negative sequences) are displayed on the web interface.

NOTE: C37.118 output control function is disabled when IEC 61850 XCBR control is enabled.

OPTIONAL SAMPLED VALUE REPORTING (IEC 61850-9-2LE / IEC 61869-9)

Specifications	Value
2x Ethernet connections	Copper or Fiber Optic (PRP supported)
2x clients IP transport	TCP/UDP or UDP spontaneous
Digital Interface Message format	IEC 61850-9-2LE - MSVCB01 (protection) and MSVCB02 (measure) IEC 61869-9 - MSVCB03 (protection) and MSVCB04 (measure) Two data streams can be published <u>simultaneously</u> no matter the format.
Data published in MSVCB	Voltage: VA, VB, VC and VN Current: IA, IB, IC and IN (Sample Timestamp and Time quality implicitly included in MSVCB.)

NOTE: The optional Sampled Value Reporting requires the PMC000200 option (refer to the smart coding document)

61850-GOOSE PUBLISHER REPORTING

Parameter	Value
Communication links	Ethernet1 - Ethernet2 - Redundant
Message format	IEC 61850-GOOSE
Publishing rate	Configurable by software for each block independently
DataSet published in GOOSE Control Block	<p>GOOSE Control Block 01 (gcb01) Dataset: TxGOOSE_PhysIOs Dedicated to the Physical IOs: Digital inputs (DI1 – DI10), Digital outputs (Out1 to Out6), Digital relay outputs (R1 to R4)</p> <p>GOOSE Control Block 02 (gcb02) Dataset: TxGOOSE_CB1 Dedicated to the XCBR10 GOOSE Control Block</p> <p>GOOSE Control Block 03 (gcb03) Dataset: TxGOOSE_CB1Pos Dedicated to the circuit-breaker XCBR10 position</p> <p>(Timestamp and Time quality are implicitly attached with all input/output state change in GOOSE data frame).</p>

NOTE: The PMU .icd file defining the complete device capability following the IEC 61850 standard is provided in the documentation folder of the Vizimax Tool Suite.

IEC 61850-GOOSE SUBSCRIBER WITH XCBR CONTROL MODEL

Starting firmware 1.4 and up, Vizimax unit delivered with the PMC001000 option (adding 10 digital inputs and 6 high current - high speed outputs) support the GOOSE subscriber protocol with the XCBR model, allowing controlling a 3-phase circuit breaker (independent poles).

Parameter	Value
Communication links	Ethernet1 - Ethernet2 - Redundant
Message format	IEC 61850-GOOSE Ed2
GOOSE Subscribers	Up to 32 GOOSE subscribers
Publishing rate	Configurable by software for each block independently
Virtual Inputs	Virtual inputs Control: 8 inputs (select+operate for open and close, from 2 sources) Protection: 16 trip inputs Reclosing: 2 inputs Blocking: 6 inputs (2 opening and 4 closing) Interlocking: 3 inputs (including 1 input for Synchrocheck)
XCBR Control	XCBR10 Control mode: None (Outputs are not controlled by XCBR) Independent single pole operated (IPO) Simultaneous three Pole operated (Gang operated) Control model: Status only Direct operate (with normal or enhance security) SBO (with normal or enhance security) XCBR11-12-13 Status only
Internal CSWI Control	CSWI10 Control model: Status only Direct operate (with normal or enhance security) SBO (with normal or enhance security)

NOTE: The PMU .icd file defining the complete device capability following the IEC 61850 standard is provided in the documentation folder of the Vizimax Tool Suite.

IEC 61850 MMS SERVER ED.2

Starting firmware 1.5 and up, Vizimax PMU supports the MMS server protocol:

Protocol	Characteristics
IEC 61850 MMS Server Ed.2	<ul style="list-style-type: none"> - XCBR control - Full dataset refreshed every second - 6 predefined reports (3 unbuffered + 3 buffered)

MODBUS PROTOCOL (SLAVE)

Vizimax PMU unit integrates the MODBUS slave protocol over either:

- A serial link RS232-RS485 (Modbus-RTU)
- A TCP/IP link (Modbus-TCP).

Parameter	Value
Modbus functions	01: Read Coil Status: Discrete Output Coils 02: Read Input status : Discrete Inputs/Outputs 04: Read Input Registers: Analog Input Registers 05: Force (write) Single Coil : Discrete Output Coils Note : Only when PMC001000 option is present
Modbus-TCP	TCP/IP over Ethernet port 1 or 2 User port configurable 1 to 65535 (default port number: 502 as reserved in Modbus-TCP protocol). Up to 5 simultaneous connections Output control available when PMC001000 option is present
Modbus-RTU	Over RS232 or RS485 Serial port B 300 to 115200 Baud rate Data Bits: 8, No Parity, 1 Stop bit. Slave address: 1 to 247 Output control available when PMC001000 option is present
Modbus Data Format	Value format: Integer or float Configurable 32-bits words ordering Phasor Dataset: 4/cycle or 1/second RMS Dataset: At each 'RMS Integration Time' (default 200ms)
Data Register Mapping	Refer to PMU User Guide –Appendix A Modbus mapping tables.

Please refer to the PMU support documents for details on the Modbus mapping tables.

NOTE: Modbus output control function is disabled when IEC 61850 XCBR control is enabled.

MOUNTING CONFIGURATIONS

The Vizimax Phasor Measurement Unit is available in 3 mounting configurations: standard (stand-alone), panel mount (with a 12" front panel) or a 19" rack mount.

TABLE 1 PHYSICAL DIMENSIONS

Specifications	Value
Width	257 mm/10.125 in for standard mount 305 mm/12 in for panel mount 483 mm/19 in for Rack mount
Height	92 mm/3.6 in for standard mount 105 mm/4.1 in for panel mount 3U: 132.56 mm/5.219 in for Rack mount installation
Depth	134 mm/5.25in
Weight	Standard mount 3.0 kg (6.6 lbs) Panel mount 3.3 kg (7.3 lbs) Rack mount 3.6 kg (8 lbs)

STANDARD MOUNT (STANDALONE)

The PMU standard mount is a breeze to install. It can be mounted directly inside an equipment control enclosure (Indoor or outdoor). It also includes movable mounting brackets for multiple mounting positions (horizontal or vertical).



FIGURE 4 STANDARD CONFIGURATION (STANDALONE)

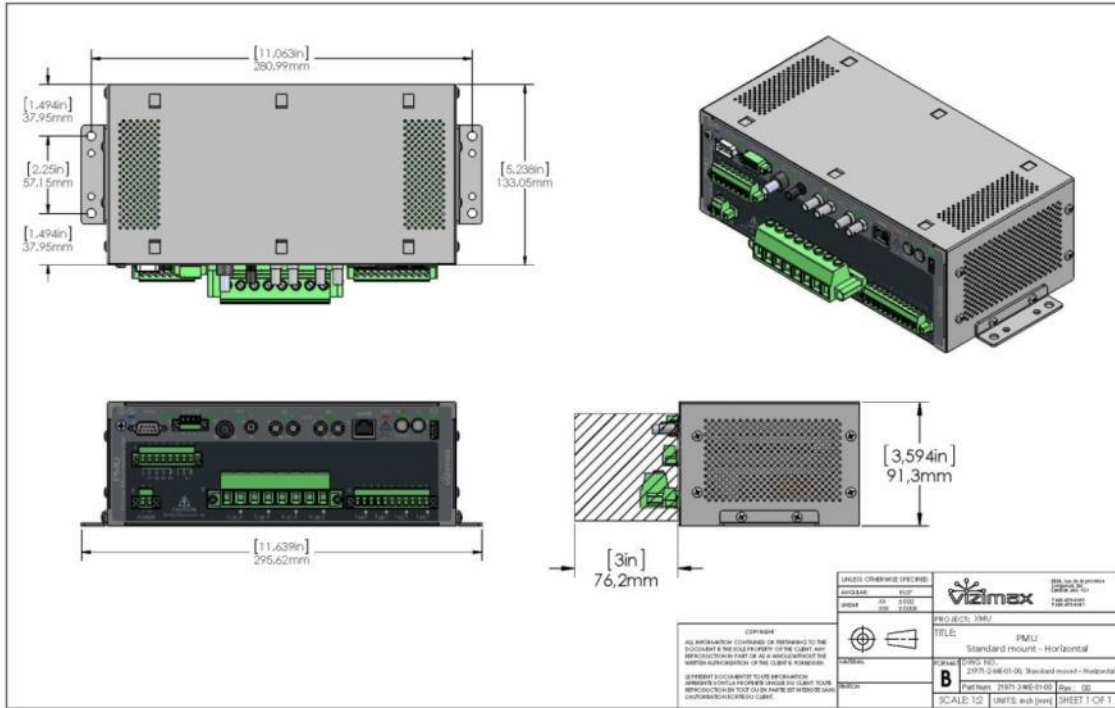

FIGURE 5 STANDARD CONFIGURATION STANDARD—HORIZONTAL

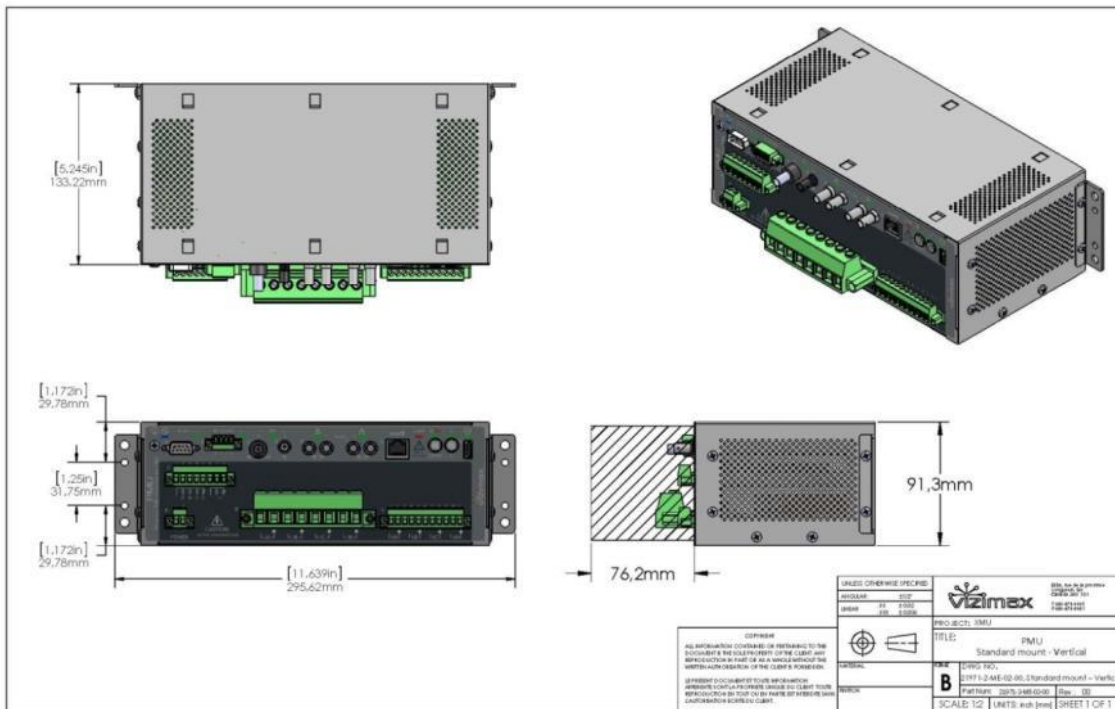

FIGURE 6 STANDARD CONFIGURATION —VERTICAL

PANEL MOUNT

The PMU panel mount is used for mounting the PMU on a metallic panel or swing door of an enclosure. It includes mounting specific brackets. The panel face plate is 104.14 x 304.8 mm (4.1 x 12.0 in).

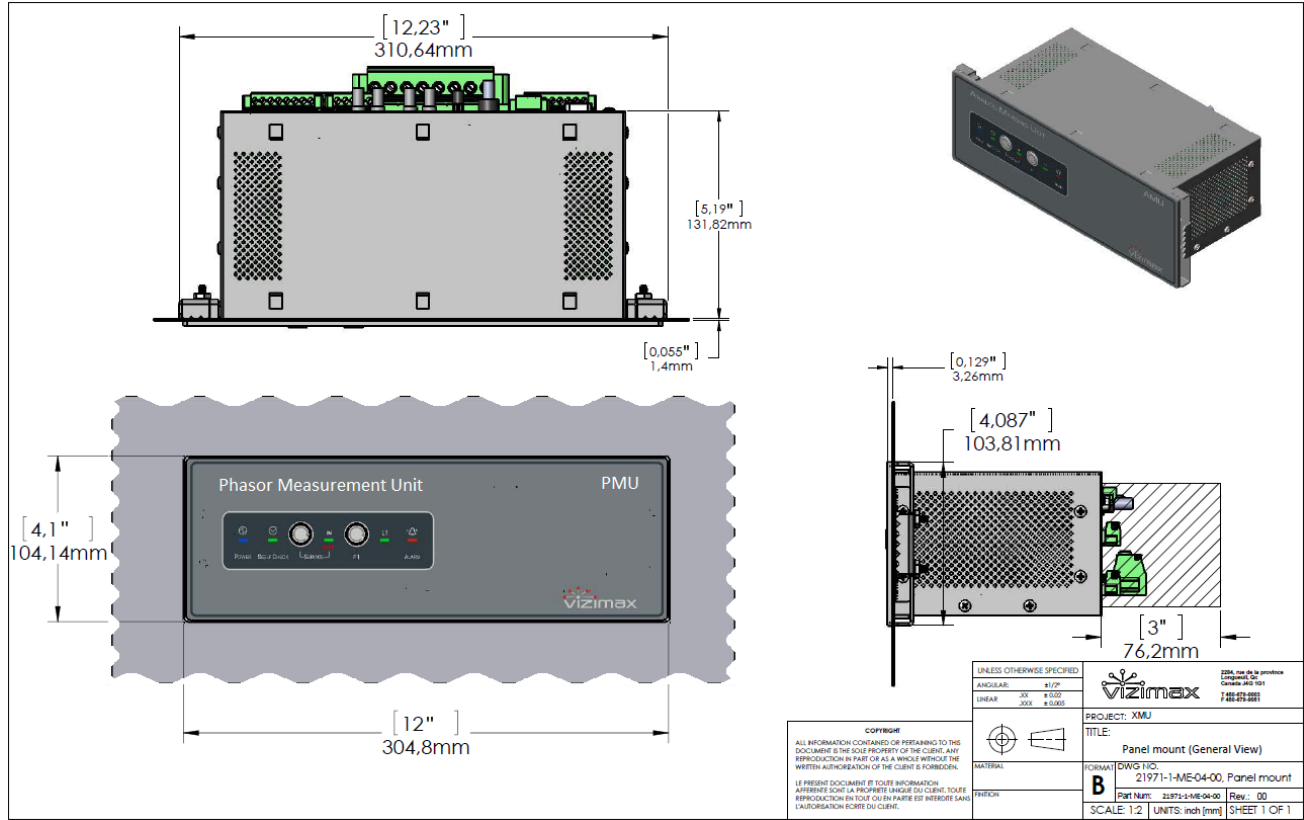

FIGURE 7 PANEL MOUNT CONFIGURATION

RACK MOUNT

The PMU rack mount is installed on an EIA 19 in rack (482.6 mm) in the substation control building. Panel size: 3U standard panel (5.219 in x 19 in).

In the configuration the Ethernet service port is relocated on the front panel.

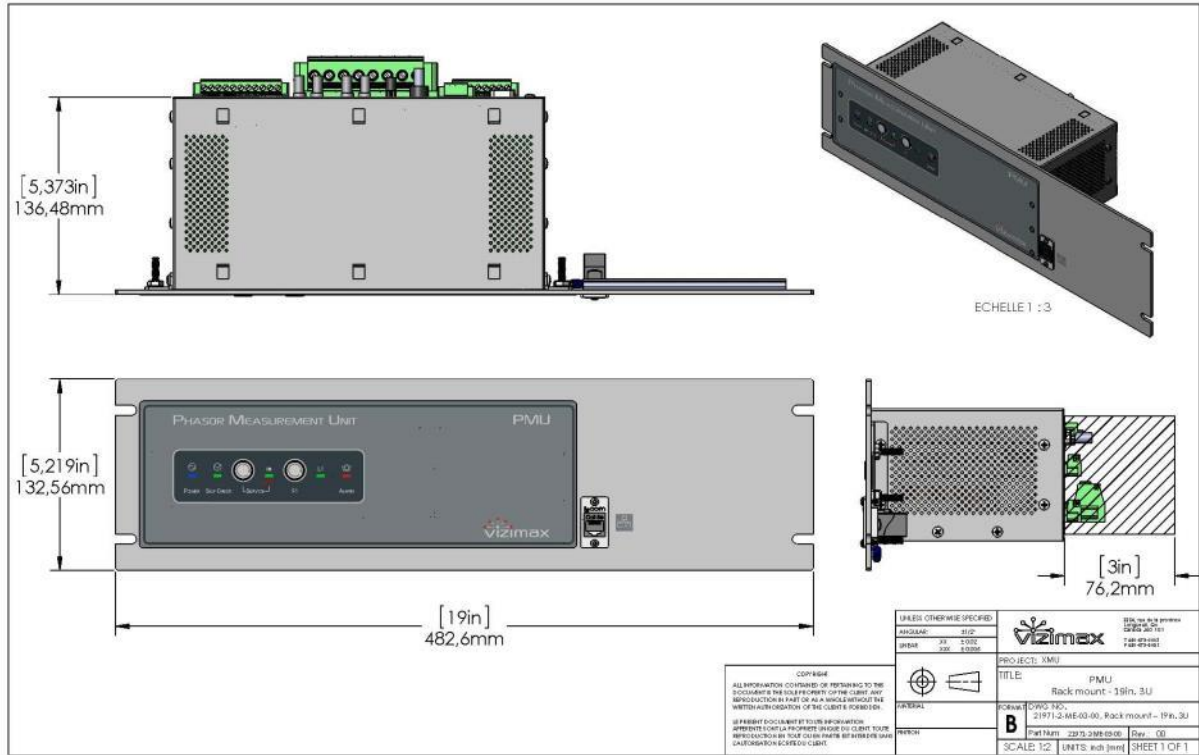

FIGURE 8 19" RACK MOUNT CONFIGURATION

A DIN rail (120 mm - 4.8 in) - is provided on the rear panel to mount terminal blocks or IED accessories.

ABOUT THE PMU-RTS (REAL TIME SIMULATION) MODEL

The **PMU-RTS** (Phasor Measurement Unit for Real-Time Simulation) is a component of the PMU product family specially designed for hardware-in-the-loop **Real-Time Simulation** environment such as OPAL-RT’s RT-LAB™ and Hypersim™, or RTDS Technologies’ RTDS®

The PMU-RTS unit offers the same functionality as the standard PMU, but the AC measuring inputs (current and voltage inputs) are compatible with a low voltage signal (10Vrms) provided by real-time simulation hardware.

Therefore, real life PMU’s applications can be fully simulated in a laboratory environment without needing expensive analog power amplifiers or high voltage discrete I/O interfaces.

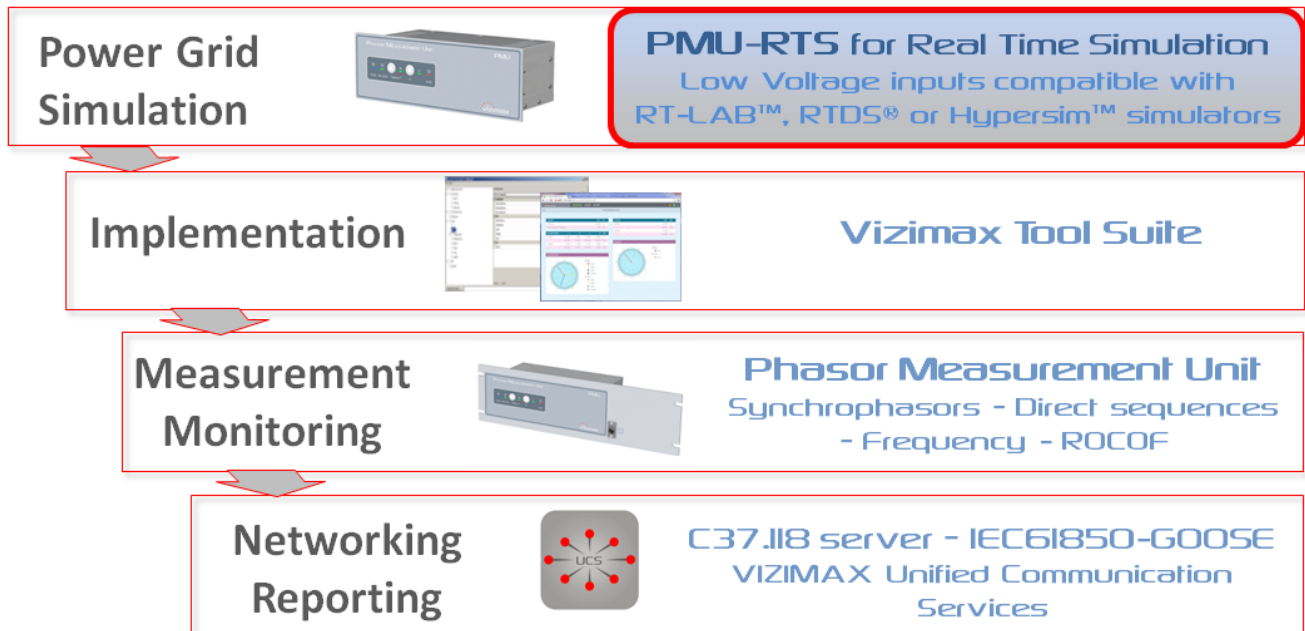

The **PMU-RTS** unit is available with the following hardware configuration:

- Power Supply: 24Vdc
- AC input current measurement: 10Vrms input range.
- AC input voltage measurement: 10Vrms input range.
- Digital inputs: 10 digital inputs
- High current – high speed digital outputs: 6 floating outputs
- Signalization outputs: 4 electromechanical relay outputs

The mechanical mounting configuration, the time synchronization and the Ethernet communication ports are customer selectable at unit order. Please refer to the Smart coding document (PMU010000-SC) for more details on the available options.

SPECIFICITIES FOR THE PMU-RTS PRODUCT

POWER SUPPLY (FOR PMU-RTS MODEL)

Parameter	Value
Power supply rating (24 V)	12 V dc - 36 V dc (Universal 24V dc power supply adapter (100-240V ac/ 50-60Hz) included with PMU-RTS unit).
Rated power	29 W max. (typical 18 W)
Connector	Phoenix MSTB 5.08 mm
Isolation	3000 V during 1 s
Fuse	Time delay, 2 x 2 A (not user serviceable)
Maximum Voltage interrupt	100 ms @ 100%

NOTE: This table is applicable to PMU-RTS model only.



DIGITAL INPUTS (FOR PMU-RTS MODEL)

The PMU-RTS offers 10 digital inputs split in 2 groups, one of 6 inputs with one common and a group of 4 with their own common.

Parameter	Value
Name	DI1 to DI10
Number of inputs	10 (4 on connector M + 6 on connector N)
Maximum input voltage (24V power supply)	36 V dc, (detection threshold 10 V dc)
Isolation	Opto-coupler, 2000 VRMS
Measuring Category	MEAS CAT IV
Burden	2 mA to 5 mA
Maximum Hardware response Time	0.10 ms at nominal voltage 1.00 ms at 80% of nominal voltage
Software Filter	Programmable, 1 ms increments up to 250ms. Advanced chatter filter
Connector	Phoenix MSTB 5.08mm, pluggable screw type.

NOTE: This table is applicable to PMU-RTS model only.

HIGH CURRENT DIGITAL OUTPUTS (FOR PMU-RTS MODEL)

The PMU-RTS offers 6 high current digital outputs.

Parameter	Value
Name	Out1 to Out6
Number of outputs	6 (3 on connector K + 3 on connector L)
Output driver technology	Solid State, independent, sourcing or sinking outputs
Rated voltage	10 V dc -280 V dc
DC rated Output current	5 A dc continuous, 22 A for 1s, 35 A for 200 ms, 70 A pulsed 10 ms
Maximum breaking current	7A @ L/R=40ms
Isolation	2000 VRMS
Switching Frequency	Up to 20Hz (with 100 kΩ load) Up to 250Hz (with current load >1A)
Over Voltage Category	OVC CAT III
Connector	Phoenix MSTB 5.08mm, pluggable screw type

NOTE: This table is applicable to PMU-RTS model only.

ANALOG CURRENT MEASUREMENT INPUTS (FOR PMU-RTS MODEL)

PMU-RTS model: To be compatible with the simulator's output signals, the AC current measurement inputs have been converted and scaled to receive a 10 VRMS signal.

Parameter		Value
Number of inputs		4
Name		IA, IB, IC and IN
Connector type		Phoenix PC-6, 10.16mm, pluggable screw type AWG 7-18 (10.5 mm ² – 0.75 mm ²)
Voltage	Rated voltage	10 V ac (whatever the rated current 1A or 5A selected in the application configuration file)
	Saturation voltage	10.6 V ac
	Maximum voltage	10.6 V ac
Measurement category		Not Isolated
Maximum Burden @ rated voltage		0.01 VA @ 10V
Isolation		NA. Negative side connected to P.E.
Measurement accuracy with 100% asymmetrical current		Typical: 100% Guaranteed: 100%
Nominal frequency range		40 Hz to 70 Hz
Measurement bandwidth (-3 dB)		DC to 3 kHz
Sampling frequency		19200/s
Conversion resolution		16 bits
CT angle compensation parameter		±1.00 degree
CT magnitude compensation factor		x0.01 to x1000
Hardware Accuracy		Typical: ±0.03% @ 25 °C + (±6PPM/°C) Guaranteed: ±0.1% @ 25 °C + (± 20PPM/ °C) after 15 minutes warm-up and above 1 V ac
Synchrophasor Accuracy Magnitude**		Typical: ±0.06% @ 25°C + (±10 PPM/ °C) Guaranteed: ±1.0% @ 25 °C + (±15 PPM/ °C) after 15 minutes warm-up and above 1 V ac
Synchrophasor Accuracy Angle**		Typical: ±0.05 degree @ 25 °C + (±6PPM/°C) Guaranteed: ±0.5 degree @ 25 °C + (± 20PPM/ °C) after 15 minutes warm-up and above 1 V ac

NOTE: This table is applicable to PMU-RTS model only.

NOTE:()** Estimated value confirmed by all test sequences performed during C37.118 certification.

ANALOG VOLTAGE MEASUREMENT INPUTS (FOR PMU-RTS MODEL)

PMU-RTS model: To be compatible with the simulator’s output signals, the AC voltage measurement inputs have been scaled down to 10 VRMS.

Parameter	Value
Number of inputs	4
Name	VA, VB, VC and VN
Connector type	Phoenix MSTB 5.08 mm, pluggable screw type AWG 13-24 (2.5 mm ² – 0.2 mm ²)
Rated voltage	10 V ac (whatever the rated voltage L-N selected in the application configuration file)
Saturation Voltage	10.6 V ac
Thermal capacity	10.6 V ac
Measurement category	MEAS CAT IV (0 – 150 V ac)
Maximum Burden	0.05 VA
Isolation	1500 VRMS
Nominal frequency range	40 Hz to 70 Hz
Measurement bandwidth (-3 dB)	DC to 3 kHz
Sampling frequency	19200/s
Conversion resolution	16 bits
PT angle compensation parameter	±1.00 degree
PT magnitude compensation factor	x0.01 to x1000
Hardware Accuracy	Typical: ±0.05% @ 25°C + (±10 PPM/ °C) Guaranteed: ±0.1% @ 25 °C + (±15 PPM/ °C) after 15 minutes warm-up and above 1 V ac
Synchrophasor Accuracy Magnitude**	Typical: ±0.06% @ 25°C + (±10 PPM/ °C) Guaranteed: ±1.0% @ 25 °C + (±15 PPM/ °C) after 15 minutes warm-up and above 1 V ac
Synchrophasor Accuracy Angle**	Typical: ±0.05 degree @ 25°C + (±10 PPM/ °C) Guaranteed: ±0.5 degree @ 25 °C + (±15 PPM/ °C) after 15 minutes warm-up and above 1 V ac

NOTE: This table is applicable to PMU-RTS model only.

NOTE:()** Estimated value confirmed by all test sequences performed during C37.118 certification.

NOTE: All other specifications are similar to standard PMU model

ORDERING INFORMATION

PMU010000: Phasor Measurement Unit (PMU)

PMU base unit includes: 4x CT inputs (1A or 5A) + 4x PT inputs + 4x digital signaling outputs (2x Form C + 2x Form A) + 2x serial ports + 3x RJ45 Ethernet 100BASE-T ports (1 reserved for service port) + 2x PPS/IRIG-B inputs (1x fiber optic ST input + 1x BNC input/output): Support IEEE C37.118-2.2011 (and 2005), IEC 61850-GOOSE publisher, IEC 61850 MMS Server Ed.2 and Modbus (slave) protocols.

When ordering your PMU, the following configuration options must be defined: mounting configuration, power supply voltage and CT's inputs rating current.

Other additional options are also available:

Option PMC010000: Ethernet ports 1 and 2: Replace 2xRJ45 by 2x Fiber Optic ST multimode

Option PMC020000: Ethernet ports 1 and 2: Replace 2xRJ45 by 2x Fiber Optic LC single mode

Option PMC021000: Ethernet ports 1 and 2: Replace 2xRJ45 by 2x Fiber Optic LC multimode

Option PMC001000: Add ten (10) digital inputs and six (6) high current digital for Circuit breaker control. This option enables the IEC 61850 GOOSE subscriber protocol with XCBR control model.

Option PMC000100: Add built-in GPS receiver

Option PMC000200: Add IEC 61850-9-2LE / IEC 61869-9 sampled values (SV) reporting

Please refer to the 'smart coding' document 'PMU010000-SC' for more details about all PMU options or PMU-RTS model.

To download the PMU smart coding document, please use the following link:

<https://www.vizimax.com/publications/>

Vizimax also offers commissioning and training services: for more details, please contact us.

NOTE: These specifications are subject to change without prior notice.



Support contact:

mu.support@Vizimax.com
www.Vizimax.com/support

Vizimax, the Vizimax logo, RightWON, WiseWON, SynchroTeq, SynchroTeq Plus and the RightWON icons are trademarks or registered trademarks of Vizimax, Inc. in Canada, the United States and other jurisdictions. All other trademarks, registered trademarks and service marks are the property of their respective owners.

V-FOPR03-011en (2016-03-22)