



SYNCHROTEQ[®] LITE UNIT

DATASHEET



(19" rack mount model shown here)

STL010000

2024-04-30

©2024 VIZIMAX Inc. All rights reserved

TABLE OF CONTENT

| | |
|--|-----------|
| TABLE OF CONTENT | 2 |
| PRODUCT OVERVIEW | 3 |
| APPLICATIONS OF SYNCHROTEQ LITE..... | 4 |
| SYNCHROTEQ LITE HIGHLIGHT | 5 |
| SYNCHROTEQ LITE UNITS - MAJOR FEATURES | 6 |
| CONTROLLED SWITCHING | 7 |
| CIRCUIT BREAKER WEAR MONITORING..... | 8 |
| OPERATING ENVIRONMENT | 9 |
| COMMUNICATION LINKS – TIME SYNCHRONIZATION - SOFTWARE..... | 10 |
| VIZIMAX TOOL SUITE AND WEB INTERFACE | 13 |
| SYNCHROTEQ LITE CONNECTORS AND HMI IDENTIFICATION | 15 |
| TECHNICAL SPECIFICATIONS | 16 |
| POWER SUPPLY | 18 |
| CONTROL – TIME SYNCHRONIZATION - COMMUNICATION | 19 |
| AC MEASUREMENT INPUTS..... | 21 |
| DC MEASUREMENT INPUTS | 23 |
| DIGITAL INPUTS / OUTPUTS..... | 24 |
| FUNCTIONAL ANALYSIS TOOLS | 28 |
| MOUNTING CONFIGURATIONS | 29 |
| PHYSICAL DIMENSIONS..... | 29 |
| STANDARD MOUNT (STANDALONE) | 29 |
| PANEL MOUNT | 31 |
| RACK MOUNT | 32 |
| ORDERING INFORMATION | 33 |

PRODUCT OVERVIEW

SynchroTeq® Lite is an extension of the SynchroTeq® Plus aimed at HV circuit breakers.

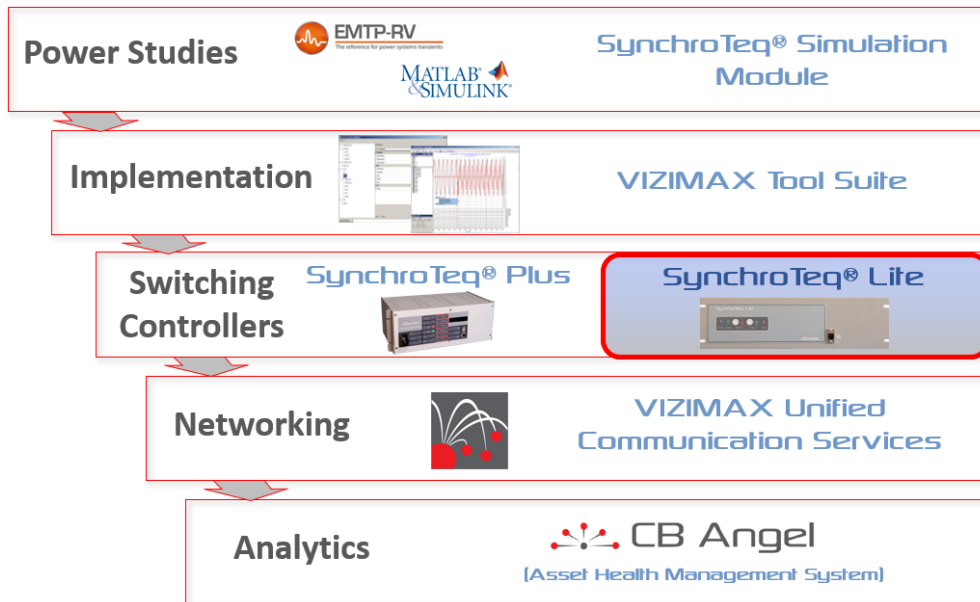

A compact Control Switching Device (CSD) for HV circuit breakers with independent pole mechanism, the SynchroTeq Lite is specifically designed for capacitor banks, shunt reactors, filters and power transformers switching projects at fixed settings.

The SynchroTeq Lite features a comprehensive set of Controlled Switching modes, and performs significantly well in a variety of applications as shown in Table 1 below:

TABLE 1 SYNCHROTEQ UNIT VS LOAD SWITCHING APPLICATION

| Load Switching Application | SynchroTeq Lite | SynchroTeq Plus | |
|---|-----------------|-----------------|----------------------------------|
| | | SynchroTeq Plus | SynchroTeq Plus + VL measurement |
| Discharged Capacitor Banks - MSC / MSCDN | ☑ | ☑ | ☑ |
| Shunt Reactors – MSR | ☑ | ☑ | ☑ |
| Power Transformers (Peak Voltage) | ☑ | ☑ | ☑ |
| Power Transformers (Residual Flux) | | | ☑ |
| Power Transformers in Parallel (Residual Flux) | | | ☑ |
| Compensated / Uncompensated Transmission lines (any kV level) | | | ☑ |
| Cables (HV, submarine) | | ☑ | ☑ |
| Partially Charged Capacitor Banks – MSC/FLT | | ☑ | ☑ |
| CB and a half (any kV level) | | ☑ | ☑ |
| Voltage range | Up to UHV | | |

SynchroTeq Lite is also a manufacturer agnostic solution suitable for ‘DC controlled’ spring mechanism circuit breakers (C/Bs) or load break switches regardless of the make.

APPLICATIONS OF SYNCHROTEQ LITE

The outstanding performance of SynchroTeq Lite devices apply to a variety of HV circuit breakers – regardless of the make – and can be leveraged for optimized switching of shunt reactors, capacitor banks, harmonic filters and power transformers at peak voltage (fixed settings without residual flux calculation).

Among other applications, SynchroTeq Lite is a powerful, communication-enabled IED suitable for:

- **Renewable Power Generation:**
 - Switching reactive loads in standalone.
- **Conventional Power Generation:**
 - Switching reactive loads.
- **Industry:**
 - Electrical Arc Furnaces: MSC/MSR/FLT in SVC, reduction of switchgear wear, preservation and lifespan improvement of switchgears.
 - Transportation & Railways: energizing capacitor banks for VAR Compensation.
 - Oil&Gas: Capacitor bank switching.
- **Equipment / FACTS:**
 - Switching of capacitor banks (MSC), shunt reactor switching (MSR), harmonic filters (FLT).
 - Capacitors bank switches for PF Correction/VAR Compensation.
- **Power Grids:**
 - Capacitor bank switching.
 - Shunt reactor switching.

SYNCHROTEQ LITE HIGHLIGHT

- **Advanced controlled switching:** intended for HV capacitor bank, shunt reactors and filters.
- **Manufacturer agnostic solution:** for spring mechanism circuit breakers (C/Bs) or load break switches, regardless of the make.
- **Monitoring tools:** i^2t , web operational interface, event analyzer, waveform viewer.
- **C/B timing compensation:** control voltage, temperature, idle time, adaptive control.
- **Strong Engine, Web-based operation:**
 - 500 events and waveforms storage
 - Secured Web-Based interface
- **Data transfer for SCADA / DCS:**
 - Native IEC61850 server MMS including XCBR control model.

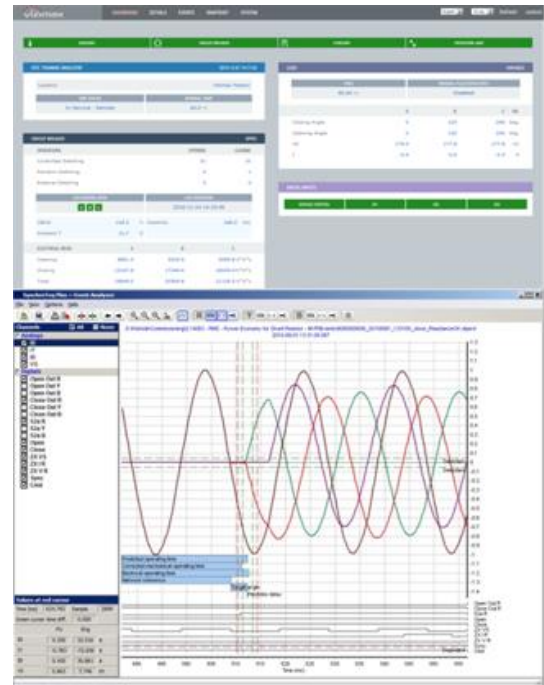

SYNCHROTEQ LITE UNITS - MAJOR FEATURES

| Features | SynchroTeq Lite |
|--|--|
| Circuit breaker coils control outputs | 6x Coil control outputs (3x Open + 3x Close coils) |
| AC current inputs | 3x AC current measurement inputs (1 or 5 A) |
| AC voltage inputs | 1x AC voltage input for source voltage measurement and synchronization |
| Digital Inputs | 10x digital inputs: <ul style="list-style-type: none"> • Three inputs for C/B contact position (52a contacts) • Two inputs for C/B control (OPEN/CLOSE commands) • One input to set SynchroTeq Lite Out of Service • One input to set SynchroTeq Lite in Local / Remote mode • Three programmable inputs for C/B monitoring and commands |
| Compensation inputs | 2x C/B timing compensation inputs: <ul style="list-style-type: none"> • Temperature input (RTD or 4-20 mA from external sensor) • C/B coil voltage input |
| Signalization Outputs | 4x dry contact relay outputs: Alarms and Bypass |
| Power Supply | 24Vdc or 48Vdc or 110Vdc or 125Vdc or 220Vdc |
| Local user Interface | <ul style="list-style-type: none"> • Two push buttons (rear and front panel) • Five LEDs (front panel) – Seven LEDs (rear panel) |
| Communications ports | <ul style="list-style-type: none"> • 1x USB port • 2x 100Base-TX Ethernet • 1x RS-232 Serial port • 1x RS-485 Isolated Serial port |
| Time synchronization | <ul style="list-style-type: none"> • NTP - SNTP time server on Ethernet • IEEE PTP 1588 clock source on Ethernet • IRIG-B clock source using the optional IRIG-B RWC0Y0001 module: <ul style="list-style-type: none"> • IRIG-B000/B004 IEEE C37.118 • IRIG-B000/B004 IEEE-1344 • IRIG-B003 • Manual synchronization from PC computer |
| Native protocol | <ul style="list-style-type: none"> • IEC 61850 server MMS <ul style="list-style-type: none"> • XCBR control • Full dataset refreshed every second • 4 predefined unbuffered reports • 120 COMTRADE waveform retrieval. |
| C/B wear monitoring | <ul style="list-style-type: none"> • Electrical wear monitoring (i²t) including warning and alarm function. • Mechanical wear monitoring including warning and alarm function |
| Functional tools | <ul style="list-style-type: none"> • Event capture (up to 500 events including COMTRADE compatible waveform files) • SynchroTeq Event Analyzer • Secured web interface |

CONTROLLED SWITCHING

SynchroTeq Lite units perform the controlled closing and/or opening of circuit breaker poles. They are applicable to multiple circuit breaker types and operation modes:

- Single pole operation with independent mechanism (IPO).
- Three pole operation with pole staggered

Closing/Opening circuit breaker poles at optimal angles (individually) results in a dramatic reduction of inrush currents, voltage transients and stresses, thus improving the quality of power delivery and preserving the health/lifespan of all assets such as circuit breakers, reactive loads and apparatus.

When receiving a command (OPEN or CLOSE) SynchroTeq Lite intercepts either a zero-crossing of the source voltage or a zero-crossing of the current, whichever is appropriate, for accurate switching synchronization. SynchroTeq Lite then computes and executes a delay/timer consisting of:

- A predicted circuit breaker operation time taking into account variations due to operating conditions, idle time, as well as timing measurements observed during previous operations (adaptive control for mechanical wear) and pole pre-arcing & arcing times (to avoid re-ignition while opening). When applicable, operation times are calculated for each individual pole.
- A synchronization delay,

Circuit breaker coil control output signals are then generated at very precise instants within the wave. The targeted electrical switching instants are determined according to the controlled switching strategy applicable to the considered load.

CIRCUIT BREAKER WEAR MONITORING

SynchroTeq Lite is not only a CSD, but also a circuit breaker monitoring tool that drastically reduces the C/B maintenance costs by allowing for scheduling maintenance only when required due to excessive wear.

SynchroTeq Lite offers 2 C/B monitoring functions:

- **Electrical wear monitoring**

For each phase, SynchroTeq Lite measures the electrical wear of the circuit breaker at each operation (i^2t), including protection and local switching operations. The i^2t value for each phase is reported in the switching operation event. The accumulated electrical wear for each phase is also computed and stored in the unit and displayed by the web interface or the configurator tool in remote mode.

An electrical wear alarm function can be enabled, including a warning threshold.

- **Mechanical wear monitoring**

SynchroTeq Lite counts all the switching operations (closing + opening, controlled + random + external). The accumulated values are displayed by the web interface or the configurator tool in remote mode.

A mechanical wear alarm function can be enabled, including a warning threshold.

OPERATING ENVIRONMENT

SynchroTeq Lite can be installed in the control compartments of switchgears, as well as in control & relay rooms, or in independent enclosures. It is therefore offered in rackmount versions for easy integration in 19" rack applications, or in 'panel mount' or 'standard mount' version when form factor is critical. SynchroTeq Lite is typically connected to the following subsystems:

- DC power supply: uninterruptible power source for the substation / circuit breaker control and protection equipment.
- Controlled circuit breaker: control outputs, statuses/pole positions.
- Protection relays.
- AC measurements: system/source voltage, load current.
- Condition measurements: DC control voltage, temperature.
- Local control panels, networked SCADA/DCS systems, network infrastructure: C/B control in substations or in equipment.

SWITCHING OF CAPACITOR BANK OR SHUNT REACTOR

SynchroTeq Lite is intended for the controlled switching of shunt reactors, discharged capacitor banks and harmonic filters, all based on fixed switching angle strategies.

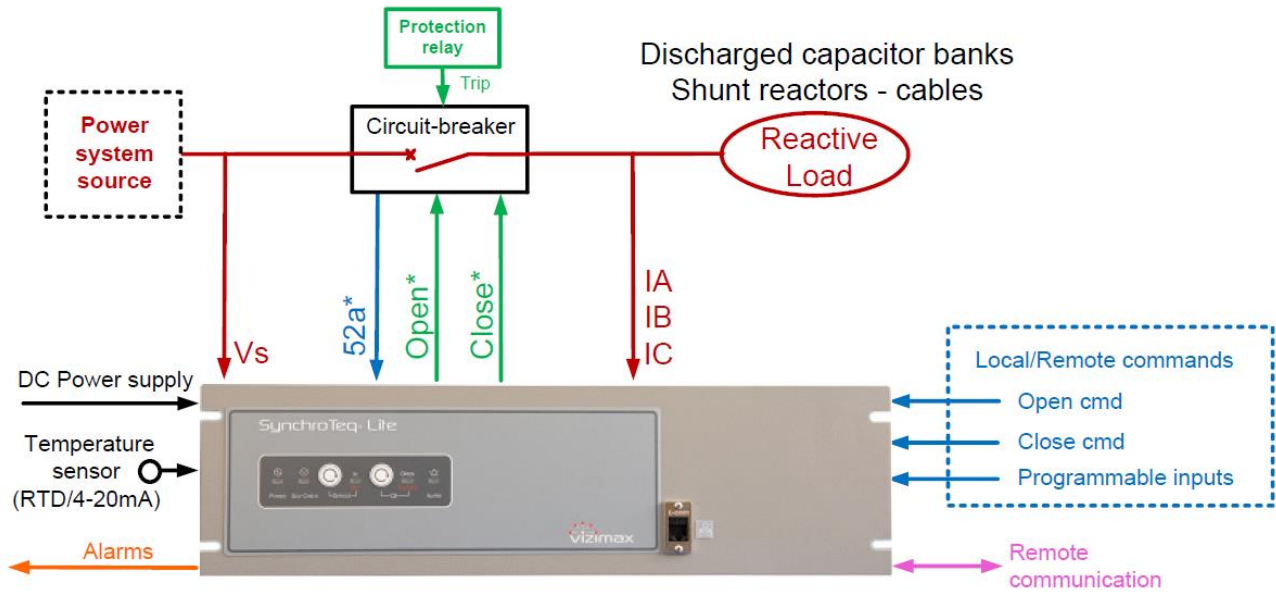

FIGURE 1 EXAMPLE OF SYNCHROTEQ LITE IN DISCHARGED CAPACITOR BANK OR SHUNT REACTOR APPLICATION

COMMUNICATION LINKS – TIME SYNCHRONIZATION - SOFTWARE

SynchroTeq Lite units feature built-in communication ports for network integration and external devices:

- Two 100Base-TX Ethernet ports:
 - Ethernet-based Service Port.
 - Ethernet-based general purpose network interface and IEC61850 MMS.
- Two serial communication ports:
 - One isolated RS-232/RS-485 port reserved for the optional SynchroTeq Communication module (RWK000016: DNP3 and MODBUS protocol support)
 - RS232 port for service operations

The communication ports are located on the rear panel, excepted for the Ethernet service port which is relocated to the front panel for the SynchroTeq Lite (rack mount version).

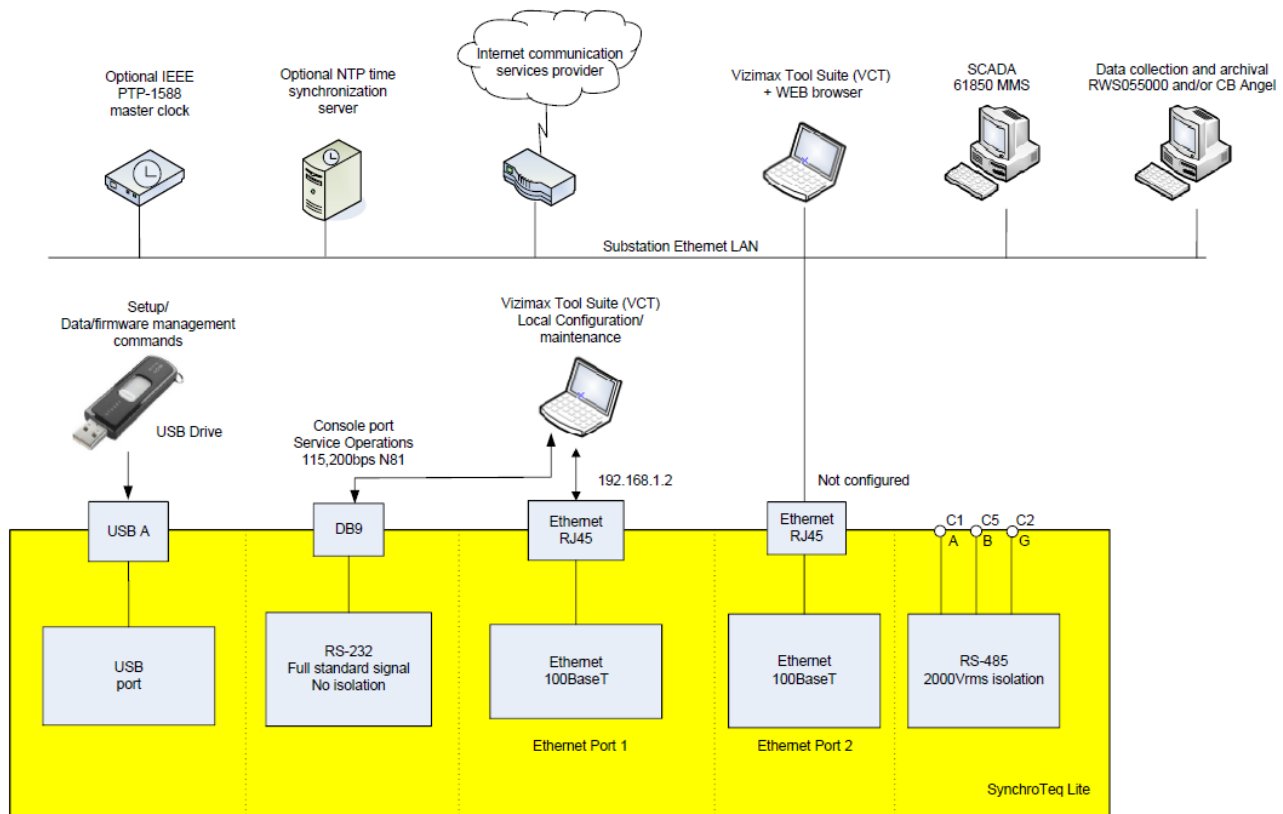

FIGURE 2 COMMUNICATION PORTS

TIME SYNCHRONIZATION

SynchroTeq Lite time synchronization can be achieved with either:

- PTP-1588 (IEEE Standard Precision Time Protocol) service over the Ethernet network. Supported profile is: "PTP/IEEE-1588v2 UDP/IPv4, Multicast, End-to-End/Peer-to-Peer, Slave Only".
- IRIG-B time synchronization protocol using the optional RWC0Y0001 module over either:
 - BNC connector with a compliant IEC 60044-8 TTL signal
 - Fiber optic ST type connector with a compliant IEC 61869-9 signal

The IRIG-B supported formats are:

- IRIG-B000/B004 IEEE C37.118
- IRIG-B000/B004 IEEE-1344
- IRIG-B003
- NTP - SNTP (Network Time Protocol) service over the Ethernet network
- Protocol using the optional SynchroTeq Communication module RWK000016.

Any one of these approaches allows to time stamp recorded operational events for remote data analysis.

FRONT PANEL / LOCAL HMI - REMOTE CONTROL

SynchroTeq Lite can be managed locally (front panel and built-in HMI) and/or remotely through either:

- The VIZIMAX Tool Suite (VCT) in remote mode
- The SynchroTeq web-based operation interface (requires a web-browser)
- IEC61850 substation automation environment (MMS protocol)
- Local or remote PC computers/servers with optional licenses of the Vizimax Unified Communication Services (RWS055000)
- Substation automation: Native IEC 61850 MMS, optional DNP3.0 and MODBUS via SynchroTeq Communication Module (RWK000016)
- Dry contacts (commands) and relay outputs (statuses).

COMMUNICATIONS AND DATA ANALYTICS SOLUTIONS

VIZIMAX offers a full set of software tools to address client requirements for communication, data transfer to central site and Data Science (Big Data Analysis).

VIZIMAX CB Angel: A fleet-wide Asset Health Management System for the predictive and proactive maintenance of HV and MV circuit breakers fitted with VIZIMAX's Controlled Switching Devices (CSDs).

- Multi-tiered computing environment
- Cloud-based or on-premise, secure web portal

VIZIMAX Unified Communication Services: CSD fleet management interface + background communication service for PC computer or server with MS-Windows operating system.

- Automatic event and data collection, transfer and storage

Please contact your VIZIMAX representative for more details on the VIZIMAX Communication and Data Analytics solutions.

SYNCHROTEQ COMMUNICATION MODULE (OPTION RWK000016)

SynchroTeq Lite natively supports IEC 61850 MMS protocol. For application requiring other substation protocols like DNP3.0 and MODBUS, VIZIMAX offers an optional SynchroTeq Communication Module (RWK000016).

Please contact your VIZIMAX representative for more details on the SynchroTeq Communication Module (RWK000016).

VIZIMAX TOOL SUITE AND WEB INTERFACE

The Vizimax Tool Suite is a user interface for configuring and operating the SynchroTeq product family. This multi-language software is composed of the following components:

- PC based configuration tool software for operation parameters (VCT);
- VIZIMAX Event Analyzer waveform viewer, which displays the waveform captured by SynchroTeq (COMTRADE format) for operation and functional analysis;
- USB port driver for the SynchroTeq product family;
- Web based local and online help site including documentation in PDF format

The Vizimax Commissioning Tool (VCT) is used to customize the operation of the SynchroTeq Lite and its Web interface using system and application configuration files. It supports both offline and online modes of operation and provides features to exchange these configuration files with the SynchroTeq Lite unit. Typically, the configuration files are designed and managed offline on a maintenance PC and are uploaded to the SynchroTeq Lite as part of the system commissioning.

The VIZIMAX Event Analyzer is a COMTRADE compatible enhanced waveform viewer that displays the waveforms and the C/B operation simultaneously.

SYNCHROTEQ WEB INTERFACE

The unit status, alarms, readings values and event list can be displayed on any PC using a Web browser such as Internet Explorer™ or Firefox™. The SynchroTeq Lite Web interface is secured (https://) and access is granted only to authenticated users.

The SynchroTeq Web interface is dedicated for remote operation, control and analysis of the SynchroTeq units. The Web interface offers several dedicated panels:

- **Dashboard:** This page displays real time status of the SynchroTeq unit, the circuit breaker and the load.
- **Details:** This page provides access to detailed statuses, including the SynchroTeq and C/B alarms and the C/B operating time predictions and electrical wear information.
- **Events:** List of the most recent 500 events recorded and stored in the SynchroTeq Lite.
- **Snapshot:** List of the most recent waveform captures manually triggered by the user.
- **System:** System page used to manage the SynchroTeq configuration files and provides hardware information.

EVENTS AND WAVEFORM RECORDING

At each switching operation, SynchroTeq Lite records current and voltage waveforms including the C/B interface signals (52a/Trip/Close/inputs/commands) over a period of 1250 ms (250 ms pre-trigger). These waveforms are part of the events list which includes alarms and operations performed on the unit (for example, alarm reset, in/out of service). Each event includes the SynchroTeq Lite’s complete status and operating environment to allow for detailed further analysis. The SynchroTeq Lite has a memory capacity of 500 events, including waveforms.

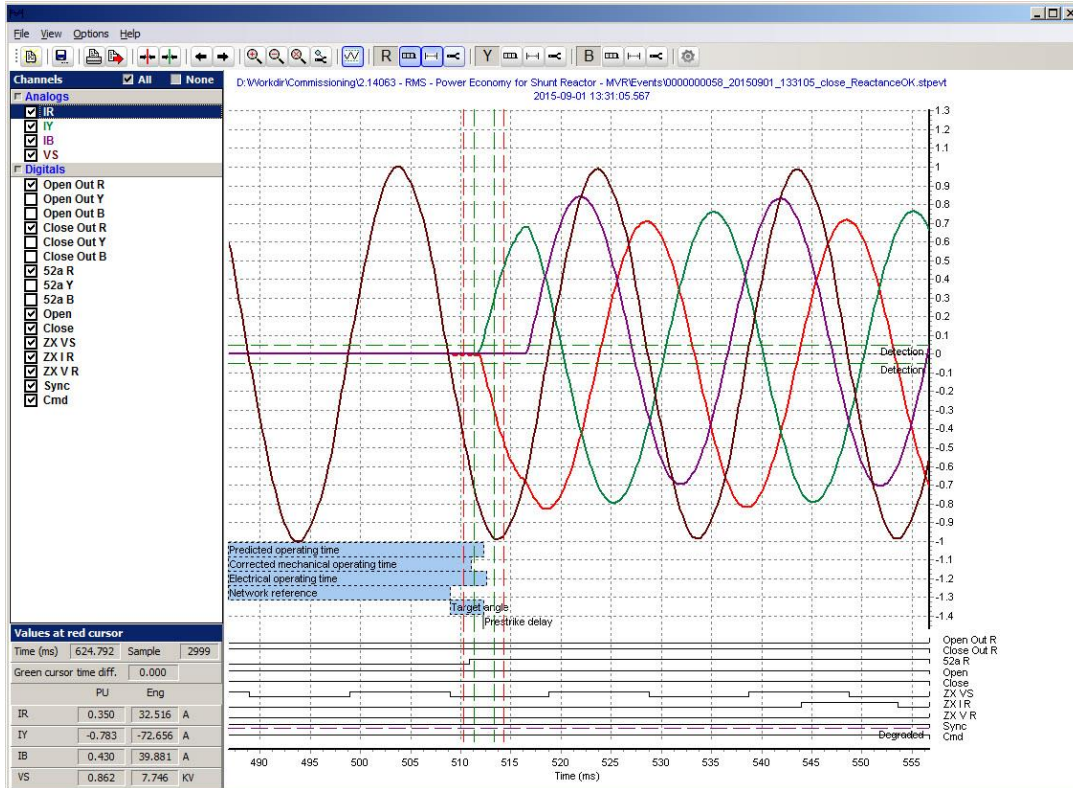
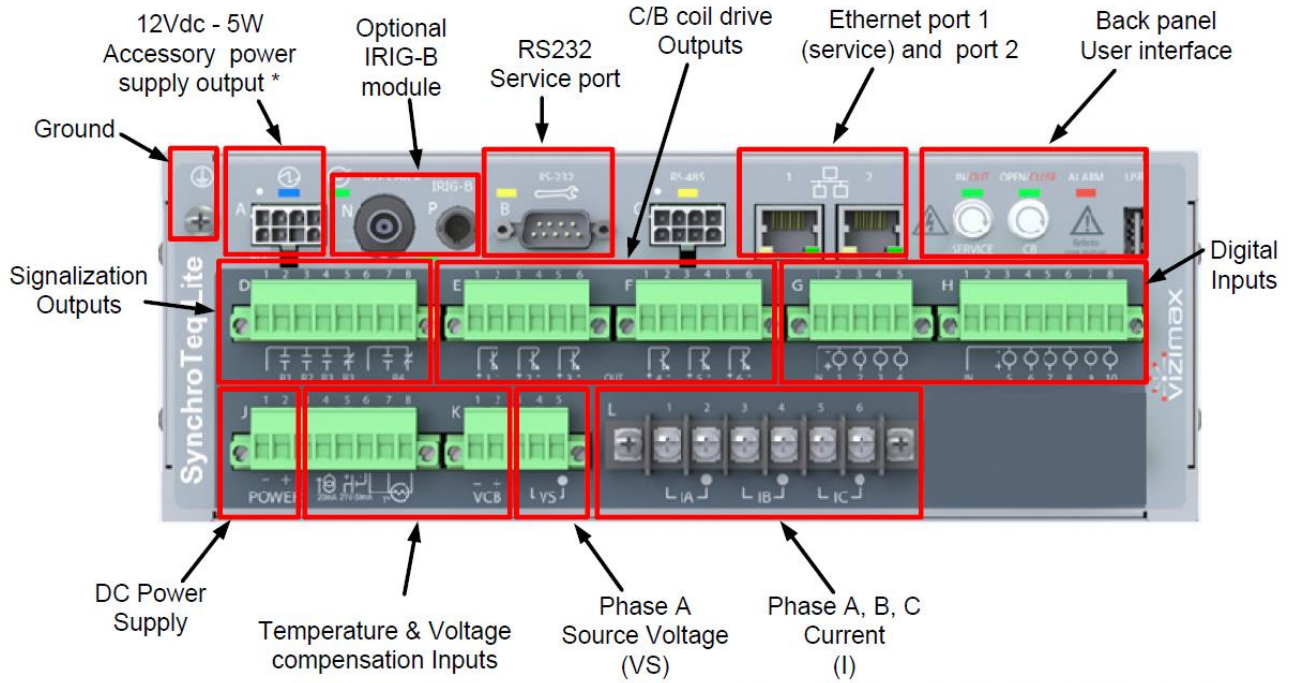

FIGURE 3 VIZIMAX EVENT ANALYZER

SYNCHROTEQ LITE CONNECTORS AND HMI IDENTIFICATION

BACK PANEL CONNECTORS IDENTIFICATION



* Was rated to 24Vdc – 5W on units delivered before May 2019.

FRONT PANEL USER INTERFACE



(rack mount version shown here)

TECHNICAL SPECIFICATIONS

COMPLIANCE AND CERTIFICATIONS



TEST TYPE

| Test type | Standard | Value |
|--------------------------------------|--|--|
| Temperature range | Operating temperature | -40°C to +85°C (*see note) |
| | Storage temperature | -50°C to +85°C |
| Maximum Relative humidity (R.H.) | IEC 60068-2-30 | 95 % without condensation |
| IP Rating | IEC 60529 | IP30 |
| Normal environmental conditions | IEC 60255-1 IEC 60947-1 | - No significant air pollution - Pollution degree 2 |
| Maximum Altitude | IEC 61010-1 | 2000 m |
| Mechanical resistance to vibrations | Performance | IEC 60255-21-1 |
| | Endurance | IEC 60255-21-1 |
| Dielectric withstand | AC Inputs and I/Os | IEC 60255-5 |
| | Communication | IEC 60255-5 |
| Impulse voltage withstand | IEC 60255-5 | 5 kV |
| Electrostatic discharge (ESD) | Air discharge | IEC 61000-4-2 |
| | Direct contact discharge | IEC 61000-4-2 |
| Damped Oscillatory Wave (1MHz burst) | Common mode | IEC 60255-22-1 |
| | Differential mode | IEC 60255-22-1 |
| Fast transients (bursts) | IEC 60255-22-4 | Level 4 |
| RF Immunity | IEC 61000-4-3 | 20 V/m, from 80 MHz to 1 GHz |
| | IEC 60255-26 | Spot Frequencies: 80 MHz to 2150 MHz |
| | ANSI/IEEE 1613 | 10 V/m, from 1.4 GHz to 2.7 GHz |
| | SN62. 1008-1 | 3 V/m, from 5.15 GHz to 5.75 GHz |
| Conducted disturbance immunity | IEC 61000-4-6 | 150 kHz to 80 MHz |
| RF emissions | CISPR 11, CISPR 22, FCC | Class A |
| Safety | IEC 61010-1, 3rd edition ISO 14971 : 2012 | Safety for measurement, control, and laboratory use |

*Internal operating temperature; please refer to 'Temperature Test Performances' table below for more details.

TEMPERATURE TEST PERFORMANCES

| Test type | | Standard | Value |
|--------------------------|------------------|----------------|--|
| Temperature Type testing | Cold | IEC 60068-2-1 | -40°C (16 hours) after cold start at -50°C |
| | Dry heat | IEC 60068-2-2 | +75°C (16 hours) |
| | Damp heat cyclic | IEC 60068-2-30 | +55°C at 95% R.H. (144 hours) |
| | UL Safety | IEC 61010-1 | -40°C to +70°C |

MEAN TIME BEFORE FAILURE (MTBF)

| Specification | Value |
|---------------|--------------------|
| MTBF | 28 years estimated |

POWER SUPPLY

The power supply is set in factory according to the ordering option.

| Parameter | Value |
|-----------------------------|---|
| Power supply rating (24 V) | 20 V dc - 35 V dc |
| Power supply rating (48 V) | 36 V dc - 72 V dc |
| Power supply rating (110 V) | 70 V dc - 140 V dc |
| Power supply rating (125 V) | 100 V dc - 140 V dc |
| Power supply rating (220 V) | 180 V dc - 280 V dc |
| Rated power | 15W max. (typical 9W, 0.07 A @ 125 V dc) – Idle 6W - The external power supply must be able to sustain a 6A cold start current for 50ms at unit start up (See note below). - When a SynchroTeq Communication Module (RWK000016) is powered by the SynchroTeq Lite accessory power supply output (connector A), the external power supply must be sized accordingly to feed this module. |
| Connector | Phoenix MSTB 5.08mm |
| Isolation | 3000V during 1 second |
| Fuse | Time delay, 2 x 2 A (not user serviceable) |
| Voltage interrupt (max) | 100ms @ 100% |

NOTE: The DC power supply includes a power reserve capable of sustaining a 100ms power interruption. The energy storage components may induce a 6A cold start current for 50ms at unit start up. The external power supply must be able to sustain this inrush current when energizing.

ACCESSORY POWER SUPPLY OUTPUT

SynchroTeq Lite offers an accessory power supply output rated at 12Vdc, 5W maximum and internally referred to the chassis (PE). This power supply output (connector A) is reserved for feeding power to the optional SynchroTeq Communication Module (RWK000016).

| Parameter | Value |
|----------------------------|----------------------------------|
| Power supply rating (12 V) | 5 Watts maximum recommended load |

NOTE: The auxiliary power supply was rated at 24Vdc, 3W for units manufactured before May 2019.

CONTROL – TIME SYNCHRONIZATION - COMMUNICATION

CONTROLLER AND TIME SYNCHRONIZATION

| Parameter | Value |
|----------------------|---|
| Main processor | 32-bit, 400 MHz high performance ARM processor |
| OS | Linux |
| Memory | 512 MB Flash memory / 128 MB RAM |
| I/O board controller | 32 bits, 168 MHz ARM processor with RTOS. 16-bit ADC. |
| Field upgrade | Field upgradable firmware available from VIZIMAX web site, support section |
| Real time clock | ±3 ppm initial accuracy. Stability is ± 5 ppm across the complete operating temperature range. Autonomy is 36 hours without power (no battery required) |
| RTC Synchronization | IRIG-B protocol using the optional RWC0Y0001 module LAN synchronization: NTP/SNTP or IEEE 1588 (see Note) or SynchroComm (RWK000016) |

NOTE: Several different configurations (profiles) are defined with the PTP-1588 protocol. SynchroTeq Lite supports version 2 using UDP (layer 3) as defined by: "PTP/IEEE-1588v2 UDP/IPv4, Multicast, End-to-End/Peer-to-Peer, Slave Only".

LOCAL USER INTERFACE

| Parameter | Value |
|---|--|
| Two push buttons (back and front panel) | - Open/Close - In/Out of Service |
| Seven LEDs (back panel) | Service, Circuit breaker position, Communication activity (2x), System status, Alarms and Power. |
| Five LEDs (front panel) | Service, Circuit breaker position, System status, Alarms and Power. |

OPTIONAL IRIG-B TIME SYNCHRONIZATION MODULE (RWC0Y0001)

| Specification | Value |
|---|---|
| Typical base inaccuracy | ≤ 10 μs |
| IRIG-B DCLS (Un-modulated) over Fiber Optic ST type (connector N) | Frequency range : 820 – 850 nanometers Base inaccuracy ≤ 1.0 μs + source inaccuracy |
| IRIG-B DCLS (Un-modulated) on BNC BNC type (connector P) | Input impedance : Z _{in} = 500 Ω Input level : 2.5V to 5.0 Vdc Base inaccuracy ≤ 10.0 μs + source inaccuracy |
| Voltage isolation level | 500 Vdc |
| IRIG-B formats (selectable by software) | - IRIG-B000/B004 IEEE-C37.118 (default setting) - IRIG-B000/B004 IEEE-1344 - IRIG-B003 |

COMMUNICATION PORTS

| Port | Characteristics | Value |
|---|-------------------------|---|
| USB port (back panel) | Interface compatibility | 2.0 |
| | Maximum speed | 480 Mbit/sec |
| | Connector type | Type A |
| | Voltage isolation level | N/A |
| 100Base-TX Ethernet 1 (Service port – front panel) | Interface | 10/100 Mbps |
| | Connector | RJ-45 |
| | Isolation | 1500 VRMS |
| | Name | Port 1 |
| | Function | Initial unit configuration and setup |
| 100Base-TX Ethernet 2 (User communication link) | Interface | 10/100 Mbps |
| | Connector | RJ-45 |
| | Isolation | 1500 VRMS |
| | Name | Port 2 |
| RS-232 Serial | Function | Console port, service Operations |
| | Connector | DB-9 (connector C) |
| | Bit rate | 115 kbps |
| RS-485 Isolated Serial | Function | Reserved for SynchroTeq Communication Module link (RWK000016) |
| | Connector | Molex Mini-Fit junior (connector A) |
| | Bit rate | 38.4 kbps |
| | Mode | Two wires interface (A-B) with jumper selectable 120 Ω terminations. Reference wire (0V) provided for high common mode voltage capability |
| | Isolation | 2000 VRMS |

NATIVE PROTOCOL

| Protocol | Characteristics |
|-----------------------------|--|
| IEC 61850 Server MMS | <ul style="list-style-type: none"> • XCBR control • Full dataset refreshed every second • 4 predefined unbuffered reports • 120 COMTRADE waveform retrieval. |

AC MEASUREMENT INPUTS

SynchroTeq Lite measures the following AC signals from current and voltage sensors:

- **Source voltage (VS) Phase A:** this measurement is taken from a voltage sensor located on phase A of the source side. This signal is used for the C/B operation synchronization and frequency measurement.
- **Phase A, B and C load current (IA, IB and IC):** these measurements are taken from current sensor located on either side of the switchgear to measure the load current for excessive inrush current detection, switchgear electrical closing time calculation and switchgear opening synchronization (Phase A). These inputs can be connected to either protection or measurement CTs

AC CURRENT MEASUREMENT INPUTS

| Parameter | Value | |
|------------------------------------|---|-------------|
| Name | IA, IB and IC (connector L) | |
| Number of inputs | 3 | |
| Connector type | Barrier strip, screw type 14AWG - 2.5 mm ² | |
| Rated current (In) | 50 mA to 12.5 A (usual measurement CT are rated to 1 A, 5 A) | |
| Thermal Capacity (1 minute) | 30 A | |
| Measurement category | MEAS CAT IV | |
| Maximum Burden @ rated current | 0.50 VA | |
| Isolation | 3000 VRMS | |
| Asymmetrical current | 80% after 100 ms | |
| Nominal Frequency | 50 Hz or 60 Hz | |
| Measurement bandwidth (-3 dB) | 4 Hz to 4 kHz | |
| Sampling frequency | 80 samples/cycle at nominal frequency | |
| Conversion resolution | 16-bit | |
| Accuracy | ±0.4% (±60 PPM/°C) | |
| Zero crossing detection | Range (frequency) | 40 to 70 Hz |
| | Minimum current | 50 mA |
| | Accuracy | 10 μs |
| Insensitivity to harmonic contents | Up to 25 % of 'In' for 2nd to 10th harmonics | |

AC SOURCE VOLTAGE MEASUREMENT INPUT (VS)

| Parameter | Value | |
|------------------------------------|--|---|
| Name | VS (connector K) | |
| Number of input | 1 | |
| Connector type | Phoenix MSTB 5.08mm, pluggable screw type AWG 13-24 (2.5 mm ² – 0.2 mm ²) | |
| Rated voltage (Vn) | 0 to 200 V ac (usual measurement PT CVT are rated to 69 V ac, 110 V ac, 120 V ac) | |
| Thermal capacity (1 minute) | 300 V ac | |
| Measurement category | MEAS CAT IV | |
| Maximum Burden | 0.005 VA | |
| Isolation | 2000 VRMS | |
| Nominal Frequency | 50Hz or 60 Hz | |
| Measurement bandwidth (-3 dB) | DC to 4 kHz | |
| Sampling frequency | 80 samples/cycle at nominal frequency | |
| Conversion resolution | 16-bit | |
| Accuracy | ±0.3% (± 50 PPM/°C) | |
| Zero crossing detection | Range (frequency) | 40 to 70 Hz |
| | Minimum voltage | 60% of Vn or 40 V ac depending of 'DynamicZX' parameter setting |
| | Accuracy | 10 μs |
| Insensitivity to harmonic contents | Up to 50 % of Vn for 2nd to 10th harmonics | |
| Input Impedance | 10.58 MΩ (common mode) / 21.2 MΩ (differential mode) <u>Caution:</u> units manufactured before April 4th, 2017 have VS input impedance of 1000 KΩ only. | |
| Common Mode Voltage Range | 700 V ac | |

DC MEASUREMENT INPUTS

SynchroTeq Lite performs the following functions:

- Monitor C/B operating temperature using a 4-20 mA loop powered sensor or a 100 Ohm Platinum RTD sensor installed in the C/B mechanical enclosure. SynchroTeq Lite provides an isolated 24 V dc power supply for an external 4-20mA conditioner when a remote sensor is used. The sensor has programmable limits to define out of range alarms.
- Monitor the C/B DC control voltage using a 0-300V isolated analog input.

The C/B operating time prediction can be influenced by both the ambient temperature and the C/B DC control voltage. SynchroTeq Lite automatically adjusts the OPEN/CLOSE coil commands according to the predicted time to operate the C/B at the optimal point on the wave. Compensation can be fine-tuned and activated through the SynchroTeq configuration.

TEMPERATURE COMPENSATION INPUT (USER SELECTABLE, PT100 RTD OR 4-20mA)

| Parameter | Value | |
|--------------------|--|------------------------|
| Name | RTD/4-20 mA (connector J) | |
| Number of inputs | 1 | |
| RTD | Range | -50°C to +100°C |
| | Accuracy | ±0.8 °C (± 200 PPM/°C) |
| 4-20mA | Range | 4-20mA |
| | Accuracy | ±0.4% (± 40 PPM/°C) |
| Sensor supply | 21V - 50mA output for current loop supply | |
| Connector | Phoenix MSTB 5.08mm, pluggable screw type. | |
| Measuring Category | MEAS CAT IV | |
| Input impedance | Current (4-20mA): 15 Ω | |
| Resolution | 16-bit | |
| Update rate | 1 update /sec | |

C/B COIL DC VOLTAGE COMPENSATION INPUT

| Parameter | Value |
|---------------------------|--|
| Name | VCB (connector K) |
| Number of input | 1 |
| Rated voltage | 0-300V dc |
| Connector | Phoenix MSTB 5.08mm, pluggable screw type. |
| Input impedance | 21.2 MΩ differential, 10.58 MΩ common |
| Measuring Category | MEAS CAT IV |
| Accuracy | ±0.3 % (± 50 PPM/°C) |
| Resolution | 16-bit |
| Update rate | 1 update /sec |
| Common Mode Voltage Range | 700 V ac |
| Dielectric Test | 2000 VRMS – 1 min |

DIGITAL INPUTS / OUTPUTS

DIGITAL INPUTS

SynchroTeq Lite provides 10 opto-isolated digital inputs distributed in two isolated groups:

- Three inputs for C/B position (52a contacts)
- Two inputs for the control of the C/B (OPEN/CLOSE commands)
- Five programmable inputs for C/B monitoring and commands

| Parameter | Value |
|---|--|
| Name | DI 1 to 10 (connectors G-H) |
| Number of inputs | 10 (6+4) |
| Maximum input voltage (24V power supply) | 30 V dc, (detection threshold 16 V dc) |
| Maximum input voltage (48V power supply) | 72 V dc, (detection threshold 28 V dc) |
| Maximum input voltage (110V power supply) | Max: 140 V dc Threshold: 52a inputs: 56 V dc Threshold: all other inputs: 69 V dc ($\pm 10\%$) |
| Maximum input voltage (125V power supply) | Max: 140 V dc Threshold: 52a inputs: 66 V dc Threshold: all other inputs: 74 V dc ($\pm 10\%$) |
| Maximum input voltage (220V power supply) | Max: 280 V dc Threshold: 52a inputs: 113 V dc Threshold: all other inputs: 137 V dc ($\pm 10\%$) |
| Isolation | Opto-coupler, 2000 VRMS |
| Measuring Category | MEAS CAT IV |
| Burden | 2 mA to 5 mA |
| Maximum Hardware response Time | 0.10 ms at nominal voltage 1.00 ms at 80% of nominal voltage |
| Software Filter | Programmable, 5 ms increments up to 250ms |
| Connector | Phoenix MSTB 5.08mm, pluggable screw type. |

NOTE: Digital inputs operating range is set according to the ordered power supply operating range.

NOTE: For 3-phase circuit breaker with staggered pole operation with single 52a auxiliary contact, this contact must be wired on DI1 and chained in parallel on DI2 and DI3 for proper operation of several major SynchroTeq features.

CIRCUIT BREAKER COILS CONTROL OUTPUTS

SynchroTeq Lite has potential free and isolated solid state coil driver outputs to control the opening and closing of the switchgear or C/B.

SynchroTeq Lite unit has 3 CLOSE and 3 OPEN outputs allowing the control of three phase independent pole operated circuit breaker.

Since the outputs are floating type, they can either source coil current (coil common to 0V supply) or sink coil current (coil common to +DC supply).

SynchroTeq Lite unit only supports 'DC controlled' circuit-breaker.

| Specifications | Value |
|--------------------------------------|---|
| Name | Out 1 to 6 (connectors E-F) |
| Number of outputs | 6 (3+3) |
| Output driver technology | Solid State, Select Before Operate (SBO) |
| Rated voltage | 20V dc - 280 V dc |
| DC rated Output current | 5A dc continuous 22 A for 1s 35 A for 200 ms 70 A pulsed 10 ms |
| Maximum breaking current | 7A @ L/R=40ms |
| Type | Independent, sourcing or sinking outputs |
| Output pulse width (activation time) | 10 ms to 1000 ms (by programmable increments of 10 ms or 100ms) |
| Coil Output command accuracy | 10 μ s (see note *) |
| Isolation | 2000 VRMS |
| Over Voltage Category | OVC CAT III |
| Connector | Phoenix MSTB 5.08mm, pluggable screw type. |

For 3-phase circuit breaker with staggered pole operation with single mechanism, wire the control outputs from phase A only.

(*) Important note on the C/B operating time accuracy:

In the SynchroTeq unit, the coil output control command precision is +/- 10 μ s. However, it is important to understand that the overall operation precision of the breaker depends on many parameters:

- C/B mechanical scatter: Each C/B has a natural mechanical deviation on his main chamber operating times. This deviation is due to the overall imprecision in the mechanical moving parts of the breaker (shafts, gears...). It is important to mention that the mechanical deviation we are talking about (generally from 0.1ms up to several ms) refers to the "intrinsic" deviation of the mechanical operating times of the breaker main chamber under constant operation circumstances (temperature, coil voltage, pressure, humidity...).

- Availability of compensation data and their accuracy: Most of C/Bs are affected by the environmental operating parameters. If these effects are not taken into consideration, the overall C/B operation precision would be seriously degraded compared to the absolute mechanical scatter. The SynchroTeq unit is able to accurately compensate for all the operational parameters as long as the provided compensation data (generally from the C/B manufacturer) is also accurate. The SynchroTeq Lite can compensate for the ambient temperature variation, and the DC coil voltage variation. Also, the SynchroTeq Lite is embedded with powerful idle-time compensation algorithm that predicts the effect of the idle-time on the main chamber operating mechanism. In general, this idle-time compensation data is a field-built information as most of C/B manufacturers cannot provide it.

For example, let us assume the following situation:

- Circuit-breaker with a natural mechanical scatter of +/- 0.3ms under +15°C
- The only parameter that affects the mechanical operating time is the ambient temperature
- Ambient temperature operating range : from -20°C to +55°C
- No compensation curve for the ambient temperature is provided, but the C/B manufacturer stated that the effect of the ambient temperature on the main chamber operating time is +/- 2ms

In this case, since no compensation data is provided, we can expect **an overall C/B operation precision of +/- 2.31ms :**

- +/- 2ms for the ambient temperature variation
- +/- 0.3ms for the mechanical scatter
- +/- 0.01ms for the SynchroTeq unit

SIGNALIZATION RELAY OUTPUTS

SynchroTeq Lite offers 4 dry contacts digital outputs for alarming and status signalization. The outputs are arranged in two isolated groups with the following functions:

- **R1:** Out of service/Fatal alarm, form A
- **R2:** C/B Temperature or C/B DC control voltage monitoring alarm, form A
- **R3:** C/B Operation limits and inrush current alarm, form C
- **R4:** System OK (watchdog), form C. The NC contact is used to indicate that the system is failed.

| Specifications | Value |
|-----------------------------------|---|
| Number of outputs | R1 to R4 2x form A and 2x form C dry contact outputs (connector D) |
| Type: | Electromechanical relays |
| Maximum steady AC current | 3 A maximum at 250 V ac |
| Maximum steady DC current | 0.3 A maximum at 250 V dc |
| Contact ratings: | 250 V ac, 300 V dc |
| Contact breaking capacity: | 10 A at 250 V ac 8 A @ 30 V, 0.5 A @125 V, 0.3 A at 250 V dc |
| Isolation: | 5000 VRMS (coil to contacts) |
| Over Voltage Category | OVC CAT III |
| Connector: | Phoenix MSTB 5.08mm, pluggable screw type. |

FUNCTIONAL ANALYSIS TOOLS

WAVEFORM CAPTURE

| Parameter | Value |
|------------------|---|
| Memory capacity | Up to 500 events (waveforms are stored in events) |
| Capture trigger | C/B commands from SynchroTeq Lite (OPEN and CLOSE) Manual trigger using snapshot capture |
| Sampling rate | 80 samples/cycle at nominal frequency |
| Recording time | 1250 ms with 250 ms pre-trigger |
| Recorded signals | Voltage on unswitched side of C/B (1) Load current (3) C/B control commands (3 x Open, 3 x close) C/B position contacts (3 x 52a) SynchroTeq Lite command inputs (OPEN and CLOSE) Phase A synchronization (1 x I, 1 x V) |

EVENT MEMORY

| Parameter | Value |
|---|---|
| Memory capacity | 500 events, including waveforms when applicable |
| Recording trigger sources | C/B commands from SynchroTeq Lite Status change (local/remote, in/out of service, cold start, reset, etc.) Alarms (self-check, sensors, C/B timing problems, C/B interface problem, loss of synchronization signal, etc.) Configuration changes (new parameters) Operation failure (rejected commands) Manual waveform capture Operation commands to SynchroTeq Lite (alarm reset, operation counters reset, set residual flux, etc.) |
| Search and display filtering capabilities | The event display can be filtered using one or the combination the following criteria: By event sequential number By date By type (open command, close command, residual flux calculation, sensor problem, etc.) By alarm type (sensor out of range, excessive inrush current, synchronization loss, etc.) |
| Time tagging display resolution | 1 millisecond with time zone management |
| Time tagging synchronization | NTP - SNTP time server on Ethernet IEEE PTP 1588 clock source on Ethernet IRIG-B protocol using the optional RWC0Y0001 module Manual synchronization from PC computer |

MOUNTING CONFIGURATIONS

SynchroTeq Lite is available in a 19" Rack mount configuration, in Panel mount (with a 12" front panel) or in Standard mount (standalone, no face plate).



The SynchroTeq Lite unit is cooled by convection; it does not have a built in fan. For this reason, install the SynchroTeq Lite unit well away from any heat producing equipment.

PHYSICAL DIMENSIONS

| Specifications | Value |
|----------------|--|
| Width | 257 mm (10.125 in) for standard mount 305 mm (12 in) for panel mount 483 mm (19 in) for Rack mount |
| Height | 92 mm (3.6 in) for standard mount 105 mm (4.1 in) for panel mount 3U: 132.5mm (5.22 in) for Rack mount installation. |
| Depth | 134 mm (5.25 in) |
| Weight | Standard mount 3.0 kg (6.6 lbs) Panel mount 3.3 kg (7.3 lbs) Rack mount 3.6 kg (8 lbs). |

STANDARD MOUNT (STANDALONE)

The SynchroTeq Lite standard mount (SM model) is dedicated for a direct mounting inside a circuit breaker enclosure. It includes movable mounting brackets for multiple mounting positions (horizontal or vertical).

NOTE: SynchroTeq Lite Standard mount version does not include front panel interface. All connectors, ports, LEDs and command push buttons are located on the rear panel.



FIGURE 4 STANDARD CONFIGURATION (STANDALONE)

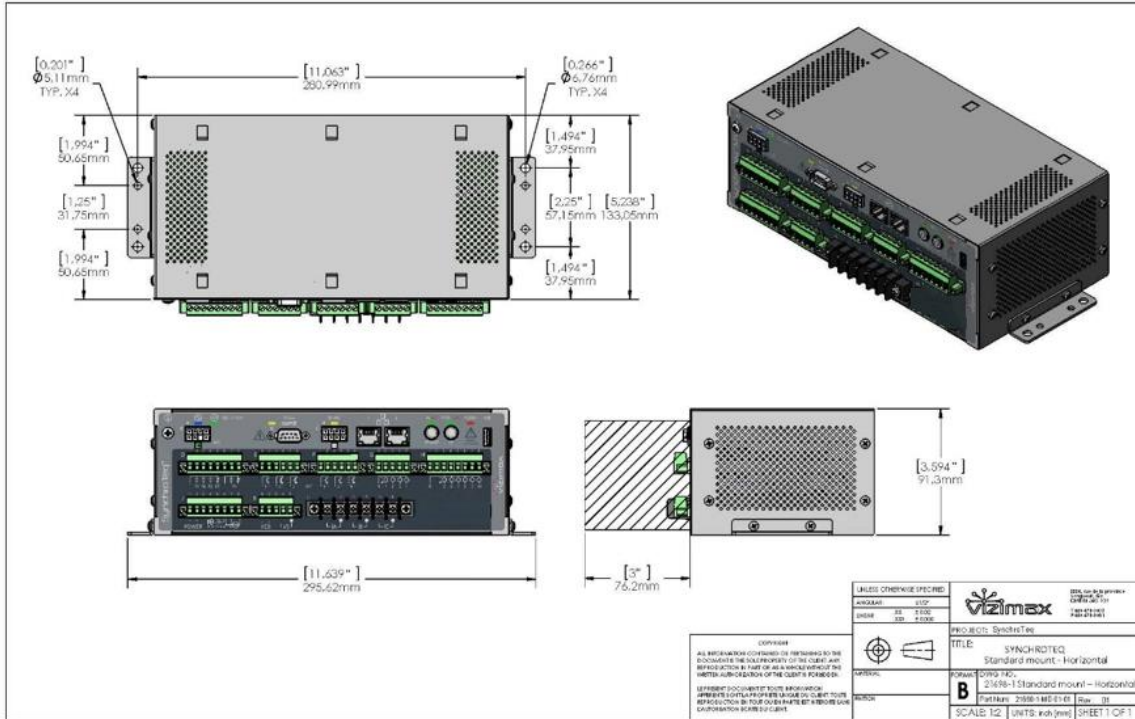

FIGURE 5 STANDARD MOUNT – HORIZONTAL

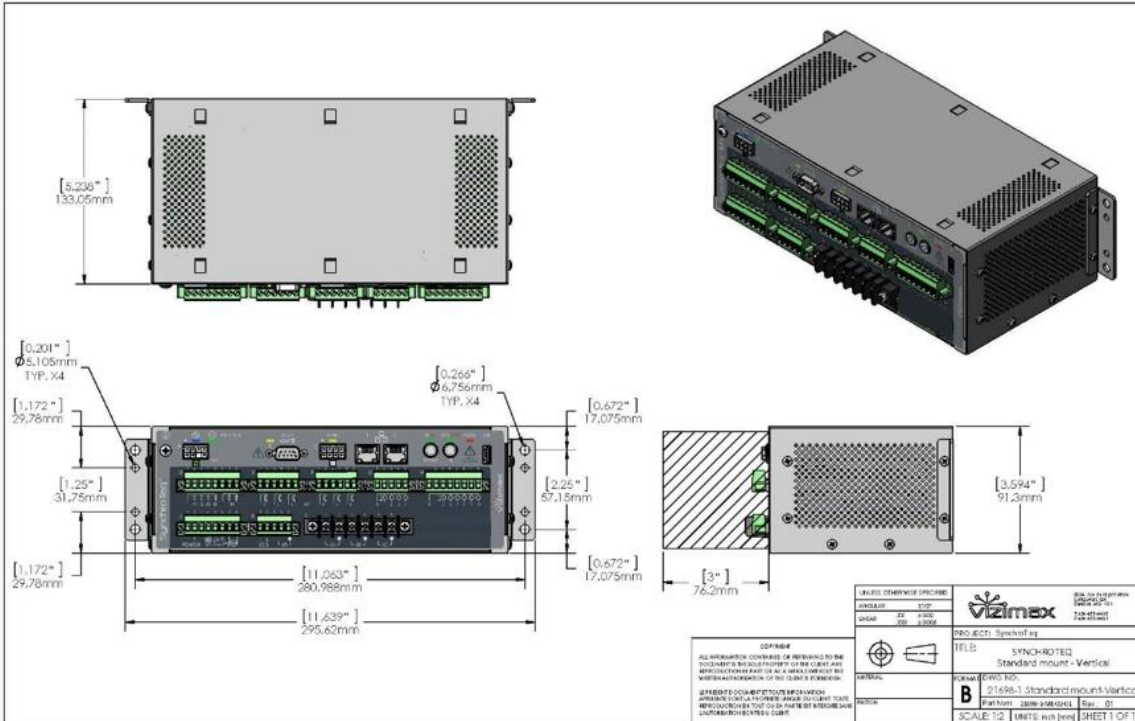

FIGURE 6 STANDARD MOUNT – VERTICAL

PANEL MOUNT

The SynchroTeq Lite Panel Mount (PM model) is for mounting to a metallic panel or swing door inside a breaker control or a switchgear enclosure. The mounting brackets are supplied with the unit. The panel face plate is 104.14 x 304.8 mm (4.1 x 12.0 in).



FIGURE 7 PANEL MOUNT

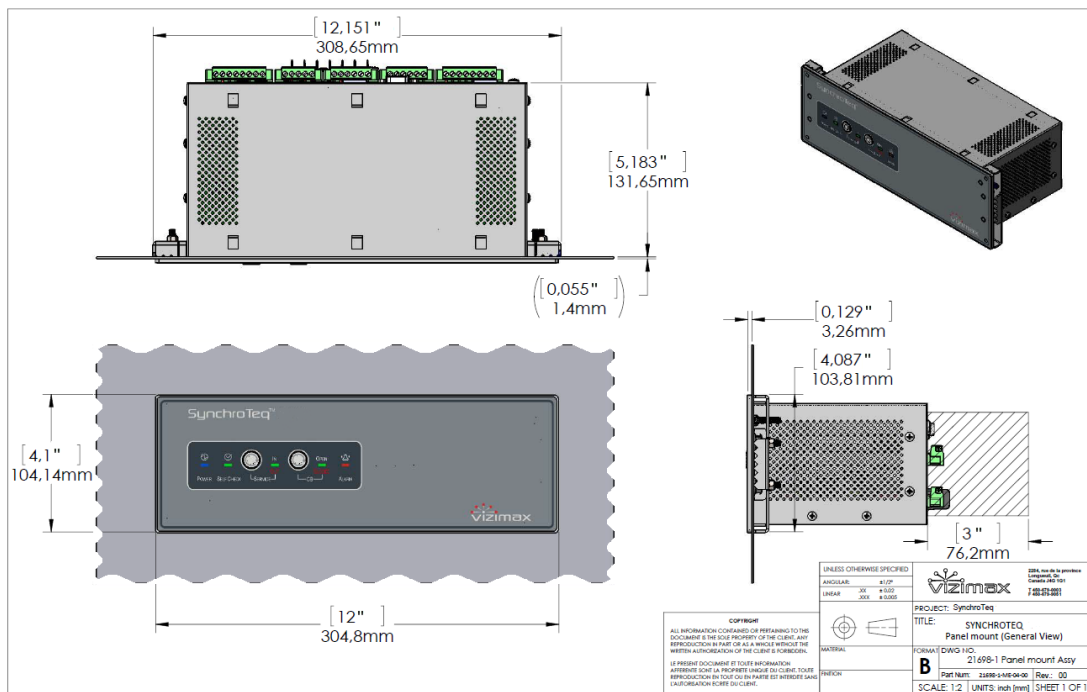

FIGURE 8 PANEL MOUNT DIMENSIONS

RACK MOUNT

The SynchroTeq Lite rack mount (RM model) is installed on an EIA 482.6 mm (19 in) rack. Panel size: 3U standard panel (5.219 x 19 in).

In this configuration, the Ethernet service port is relocated on the front panel.

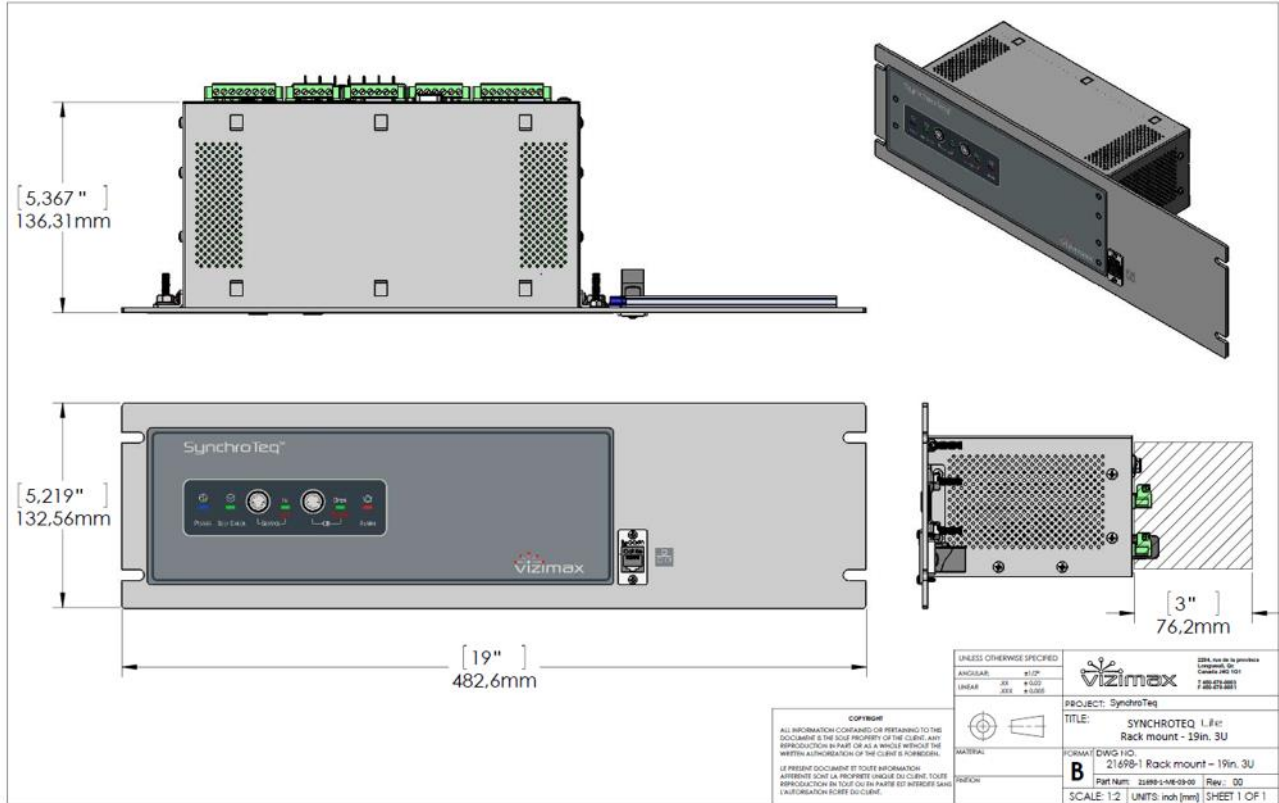

FIGURE 9 19" RACK MOUNT CONFIGURATION

A DIN rail (120mm / 4.8 in) is provided on the rear panel to mount terminal blocks or IED accessories.



ORDERING INFORMATION

STL010000 **SynchroTeq Lite** base unit (Smart Coding to be confirmed at order) for the controlled switching of shunt reactors, discharged capacitor banks and harmonic filters, all based on fixed switching angle strategies.

Please refer to the 'smart coding' document 'STL010000-SC' to select mounting configuration, IRIG-B synchronization option and power supply voltage configuration.

VIZIMAX also offers commissioning and training services: for more details please contact us.

SynchroTeq Options:

RWC0Y0001 IRIG-B time synchronization optional module over either a BNC connector with a compliant IEC 60044-8 TTL signal, or a fiber optic ST type connector with a compliant IEC 61869-9 signal.

RWK000016 SynchroTeq Communication Module including: (2x) Ethernet 100BASE-T + (1x) Ethernet 100BASE-FX multimode + (2x) serial ports and enables connection SynchroTeq Lite with DNP3.0 or MODBUS based SCADA.

RWS055000 SynchroTeq Unified Communication Services: For automatic data transfer to a centralized site of event and waveforms.

NOTE:These specifications are subject to change without prior notice.



Support contact:

st.support@VIZIMAX.com
www.VIZIMAX.com/support

Vizimax, the Vizimax logo, RightWON, WiseWON, SynchroTeq, SynchroTeq Plus and the RightWON icons are trademarks or registered trademarks of Vizimax, Inc. in Canada, the United States and other jurisdictions. All other trademarks, registered trademarks and service marks are the property of their respective owners.

V-FOPR03-011en (2016-03-22)