

SynchroTeq® Plus

Circuit Breaker Controlled Switching

Smart Coding & Options Selection

2024-12-19



A Power Grid Components, Inc. Company

Vizimax Inc

2284, de la Province - Longueuil

Québec, Canada, J4G 1G1

T: +1 (450) 679-0003 - F: +1 (450) 679-9051

www.vizimax.com

Vizimax Reference Number :

SynchroTeq Plus - base unit description (Ref : STP030000)



SynchroTeq Plus base unit includes: 12x digital inputs + 6x digital CB control outputs (3x Trip Coils + 3x Close coils) + 11x digital relay outputs + 3x PT inputs (100/√3 up to 120V) + 3x CT inputs (1A or 5A) + 5x DC analog measurement inputs (4-20mA) with compensation and/or alarm functions + 1x auxiliary analog input (configurable 4-20mA or "PT rated" AC voltage) + 2x 100BASE-T Ethernet ports + 1x RS-485 serial port. Native IEC 61850 MMS Server Ed.2 (XCBR control model), DNP3.0 and MODBUS (only one protocol can be active at a time).

1 - SynchroTeq Plus base unit configuration (Ref : STP030000)

Enter option code to complete the part number :

Choose among the following options.

a - Hardware version & Mounting

The "Standalone" version comes with a protection cover

19" Rack (to be installed in protection&control building)	RM			
Standalone (to be installed in circuit breaker cabinet)	SA			

b - Language

The selected language applies to the face plate, front display and software user interfaces

French	FR			
English	EN			
Spanish	ES			
Turkish	TR			
Chinese	ZH			

c - Voltage

The selected voltage applies to the main power supply, to all digital inputs and to digital coil control outputs

48 Vdc			1	
110 Vdc			2	
125 Vdc			3	
220 Vdc			4	

d - Current input (CT connections)

1 Amp RMS nominal current				1
5 Amps RMS nominal current (See Note 1)				5

Note 1 : 5 Amps recommended for applications with inrush currents, no matter whether the CT is 1A or 5A.

Smart coding example

SynchroTeq Plus Unit, rackmount, English version, 125Vdc, 5A CT

Consult next pages to select appropriate options.

2 - SynchroTeq Plus Communication and Synchronization options

All the options below are not included in the price of SynchroTeq Plus unit (STP030000). Additional costs may apply, please contact your sales rep for more information.

2.1 SynchroTeq Plus options - additional communication ports and synchronization module

Standard: Two Ethernet ports (copper, RJ45, 100BASE-T) + one RS485 serial port + one USB (type B) port

Description	Reference	Quantity
Ethernet port (single-mode fiber-optic, LC, 100BASE-LX10)	"1 slot" form factor (Slot T or U) RWC0P0000	
Ethernet port (multi-mode fiber-optic, ST, 100BASE-FX)	"1 slot" form factor (Slot T or U) RWC0D0000	
Ethernet port (copper, RJ45, 100BASE-T)	"1 slot" form factor (Slot T or U) RWC0C0000	
Redundant Ethernet ports for PRP* link (multi-mode fiber-optic, LC, 100BASE-FX)	"2 slots" form factor (Slot T and U) RWDPRPLC0	
Redundant Ethernet ports for PRP* link (copper, RJ45, 100BASE-T)	"2 slots" form factor (Slot T and U) RWDPRPRJ0	
IRIG-B synchronization module	"1 slot" form factor (Slot U exclusively) RWC0Y0000	

Note * : PRP - Parallel Redundancy Protocol, as defined in IEC 62439-3 and adopted by IEC 61850

All Ethernet ports (standard and additional ports) support the same services

3 - SynchroTeq Plus options - Function boards

All the options below are not included in the price of SynchroTeq Plus unit (STP030000). Additional costs may apply, please contact your sales rep for more information.

3.1 Bypass module (STP030302) control option

Standard: no bypass module

Description : SHL-1 - DCO type - Bypass module (Installed in G-H-I slots)	Reference	Select your option
Bypass module configured in 'Automatic mode' (factory default configuration) - See Note 4	STP030302 (std)	
Bypass module configured in 'Timed mode' - See Note 4	STP030302 (temp)	
Bypass module configured in 'Memorized automatic mode' - See Note 4	STP030302 (mem)	

Bypass module is an SHL "Standalone Hardwired Logic" module and is independent from the main unit.

Note 4 : By default, the bypass module is set to "Automatic Mode"; if you wish to use another mode, please select one of the available configurations. Please refer to the Bypass manual (STP030302-UG) for more details.

3.2 C/B coil control outputs (SBO - Select Before Operate) module option

Standard: standard SPSBO module with 'source' configuration shared by all 6 outputs (Installed in AA-BB slots).

Description :	Reference	Select your option
SPSBO-F module with 6 floating coil control outputs - See Note 5 (The STP030304 option is free of charge and replaces the standard SPSBO board in the AA-BB slots).	STP030304	
Dual Batteries SPSBO module - See Note 6 (The STP030305 option is free of charge and replaces the standard SPSBO board in the AA-BB slots).	STP030305	

Note 5 : This option provides 6 potential free isolated solid state outputs. These outputs are designed to 'source' or 'sink' the current from the C/B coils connected to the positive bus, or to drive a C/B electronic controller. Please refer to the STP030304-UG manual for more details.

Note 6 : This option allows to separate CLOSE and OPEN coil power supply circuits. The C/B (3)CLOSE and (3)OPEN outputs are controlled in 'source' configuration. Please refer to the STP030305-UG manual for more details.

3.3 Additional three phase voltage measurement module with residual flux calculation (STP03010x) option

Standard: no additional voltage measurement module

Description : Additional voltage measurement module (Installed in J-K-L slots)	Reference	Select your option
SPFLUX module for bushing sensors: including three (3) additional bushing sensors inputs + residual flux calculation algorithm. (This option requires an active junction box: See Note 7)	STP030101	
SPFLUX module for magnetic measurement PT: including three (3) additional PT inputs + residual flux calculation algorithm.	STP030103	

Note 7 : if you select this option, you have to select items in section 4 - SynchroTeq Plus - Bushing sensors, active junction box and connections.

4 - SynchroTeq Plus - Bushing sensors, active junction box and connections

This section must be filled ONLY if you selected the STP030101 option.

All the options below are not included in the price of SynchroTeq Plus unit (STP030000). Additional costs may apply, please contact your sales rep for more information.

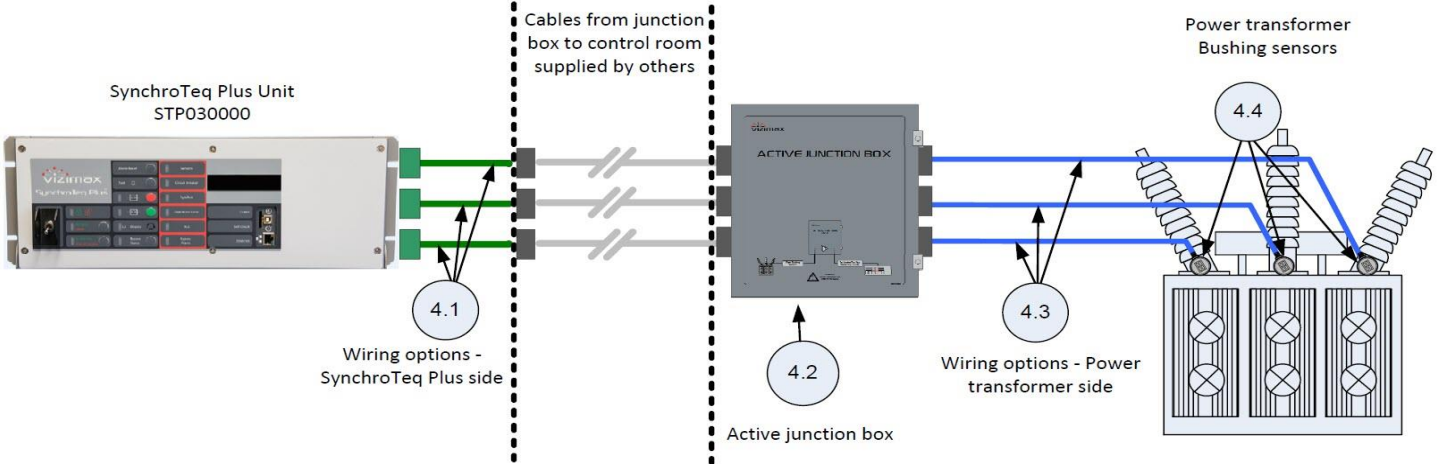

4.1 - Wiring Options - SynchroTeq Plus side

All cables are equipped and terminated for an immediate connexion to the main unit - Other side: free wires

Description	Reference
Three (3) cables - SynchroTeq Plus to terminal block - 3m/10 feet each	STP030170
Three (3) cables - SynchroTeq Plus to terminal block - 5m/15 feet each	STP030180

Select your option

4.2 - Junction box

Active junction box includes free wires connectors on SynchroTeq Plus side and power transformer side

Description	Reference
Active junction box with 3-phase connections	STP030200
Active junction box with 1-phase connection (for distant single-phase transformers)	STP030201

Quantity

4.3 - Wiring Options - Power transformer side - See Note 8

Sensor cable, with pre-assembled connector on sensor side, free wires on the junction box side

Description	Reference
One (1) cable - junction box to bushing sensor - 15m/50 feet	STP030315
One (1) cable - junction box to bushing sensor - 30m/100 feet	STP030330
One (1) cable - junction box to bushing sensor - 50m/164 feet (for very tall or distant EHV transformers)	STP030350

Quantity

Note 8 : One (1) cable per phase has to be ordered. For other cable length, please inquire

4.4 - Bushing sensors - Technical data - Mechanical fitting - See Note 9

Set of three (3) bushing sensors - one per phase - to be installed in voltage test tap on the power transformer or shunt reactor bushing.

Description	Reference
Three (3) bushing sensors for voltage measurement and residual flux calculation - See Note 9	STP030400

Select your option

Note 9 : You must fill out the 'Bushing sensor configuration' in section 6 to determine the exact type of bushing sensors.

5 - Transformers Re-energization Advisory System (TRAS)

Transformers Re-energization Advisory System allows parallel re-energization of up to three power transformers.

Please contact Vizimax's technical team for project feasibility

Description	Reference
Transformers Re-energization Advisory System available for the re-energization of two or three power transformers in parallel operated by one circuit breaker - See Note 10	BDL000004

Select your option

Note 10: Project feasibility must be confirmed by Vizimax's technical team.

6 - Bushing sensor configuration

This section must be filled **ONLY** if you selected 'Bushing sensors' in section 4.4

*The following information (6.1 to 6.4) is **MANDATORY**. If not available, please fill section 6.5 'Additional data' as much as possible.

6.1 Bushing sensors - Technical data - Electric environment*

Nominal line voltage (L-L)

Maximum voltage measurement range before clipping (limited by surge arrester); default value is 2 P.U.

Please fill the box if you wish another range value.

	kV
	PU

6.2 - C1: Bushing main capacitance to test tap*

These are generally available on the bushing's nameplate and/or test report. If not, typical values from datasheets are sufficient.

C1 bushing capacitance value

(This value applies for all 3 phases)

	pF
--	----

6.3 - C2 : Bushing test tap capacitance to ground*

These are generally available on the bushing's nameplate and/or test report. If not, typical values from datasheets are sufficient.

C2 bushing capacitance value

(This value applies for all 3 phases)

	pF
--	----

6.4 Test Tap*

Is the test tap "IEEE/ANSI Type A"?

Note: For ABB/Hitachi GOE answer Yes.

	Yes/No
--	--------

Else, provide the dimensions of the tap (diameter, depth and thread) along with a photo or a cross-sectional drawing of the tap

Diameter of tap (thread level) - inch or mm (specify)

Thread pattern - inch or mm (specify)

Depth of test tap - inch or mm (specify)

Provide a cross-sectional drawing of the tap similar to:

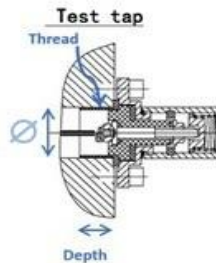

6.5 Additional data

Please fill in this section if above mandatory data is not available. Provide as much as possible:

Name of Bushing manufacturer	
Bushing model and part number	
Bushing serial number	
Place and date of manufacture	
Technical contact at bushing manufacturer (name, email, phone number...)	

Customer is required to verify upon their receipt that the sensors actually fit, to not delay the commissioning of the system in the unlikely case they do not fit and a model change is required.

For Vizimax use only

--